

Absolute Encoder Multiturn



Features

- Resolution: Singleturn: up to 16,384 (**14 Bit**) steps per revolution
Multiturn: up to 16,777,216 (**24 Bit**) revolutions
- Interface: **SSI** (synchron serial interface) or
BiSS® (bidirectional serial synchron)
SPI (serial peripheral interface)
- Output: RS 422 transceiver
- Maximum shaft diameter: **8.00 mm**
- Rotation speed: up to **10.000 rpm**



Description

The **MEM 22** is available as an absolute **multiturn** encoder in the execution of a kit system. It consists a magnetic hub, a housing unit (including the PCB) and a cable unit. The MEM 22 is a reliable low cost hollow shaft encoder that can be fixed quickly and easily on different sizes of motor shafts.

The **multiturn** encoder is developed for absolute positioning applications, for brushless motors or servo motors and steppers. The MEM 22 is a real time system for high speed applications and rough environments. The encoder is available with three different interfaces: SSI, BiSS[®] or SPI. Power supply and signals are provided by a 8 pin Molex connector.

The absolute position is detected by means of an electronic gear. The storage of the position data is done using the outsourced backup battery. The cable is thus an existential part of the encoder. Alternatively, the buffering of position data of the encoder can also be done by the customer control.

Dimensions

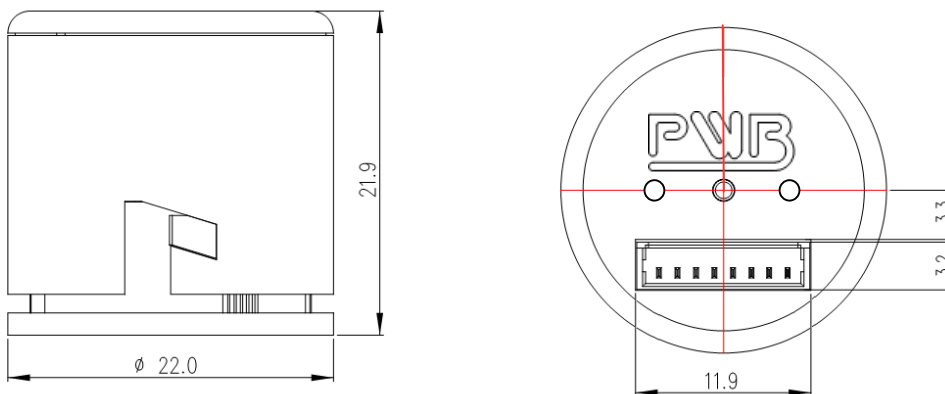

Main characteristics

- Absolute rotary encoder
- Magnetic sensing
- Multiturn by electronic gear
- Error monitoring
- Hollow shaft encoder
- High performance in compact size
- Robust plastic housing
- Quick and easy assembly
- Maximum shaft diameter: 8 mm
- Operating temperature range -40 °C to +85 °C
- Compliant EU-directive 2011/65/EU (RoHS)

Recommended operating conditions

Typical values at 25 °C.

Parameter	Symbol	Min.	Typ.	Max.	Unit	Notes
Supply voltage	U_B	4.5	5.0	5.5	V_{DC}	
Supply current	I_{LB}	40	60	80	mA	no load
Reverse polarity protection	U_B	-6.0		0	V_{DC}	
Start up time	t_T			2	ms	
Absolute accuracy			+/- 0.8		°	(after calibration via SW)
Relative accuracy			+/- 1,5		LSB	(after calibration via SW)
Rotation speed	RPM			10,000	U/min	
Acceleration	α_{max}			40	$10^3/s^2$	
ESD voltage	U_{ESD}			2	kV	discharged over 1,5k Ω
SSI / BiSS / SPI						
Clock frequency	f	80		10000	kHz	
High level output voltage	V_{oH}	2.0	3.0	5.5	V_{DC}	$R_L = 120\Omega$
Low level output voltage	V_{oL}			0.8	V_{DC}	$R_L = 120\Omega$
High level input voltage	V_{iH}	2.0		5.5	V_{DC}	
Low level input voltage	V_{iL}			0.8	V_{DC}	
Output current per channel	I_{out}	-1.0	30	50	mA	overload protection
Scan ratio of T		40		50 60	%	
Monoflop time	t_m		20 + T/2		μs	adaptive Encoder Timeout
BiSS						
CRC Polynomial			0x43		hex	$x^6 + x^1 + x^0$
CRC Start Value			0x0000		hex	
CRC Bits			6			
CDM						inverted
Environment						
Operating temperature	T_A	-40	25	85	°C	optional 100°C
Storage temperature	T_S	-40		85	°C	
Humidity exposure				90	%RH	not condensing
Vibration				2000	Hz	20 g

The angular accuracy of the datasheet can only be guaranteed by a single calibration after the mechanical assembly (with the PWB encoders Software and the USB converter box).

Electrical interface

Rotation direction clockwise (count up)

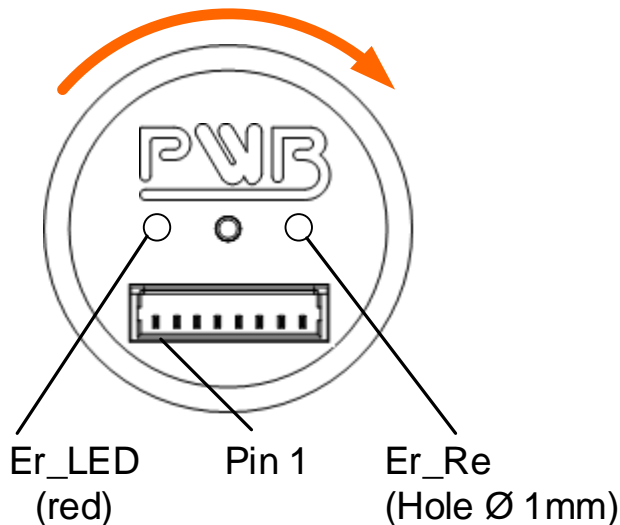

Interface SSI & BiSS

Connector Pin	Connector Signal	Cable color of wire
1	Backup +	white
2	UB	red
3	GND	blue
4	Data +	pink
5	Data -	grey
6	Clock -	yellow
7	Clock +	green
8	Backup -	brown

After assembly by the customer and after power on, the encoder can indicate an error (magnet lost). This is caused by missing the magnet during the shipment and the assembly. For erasing the error, press Er_Re in the encoder with a blunt thin object (e.g. office clip) by a unique impulse ($\geq 100\text{ms}$). Then reboot the encoder by interrupting the power supply.

Typical operating circuit (SSI & BiSS)

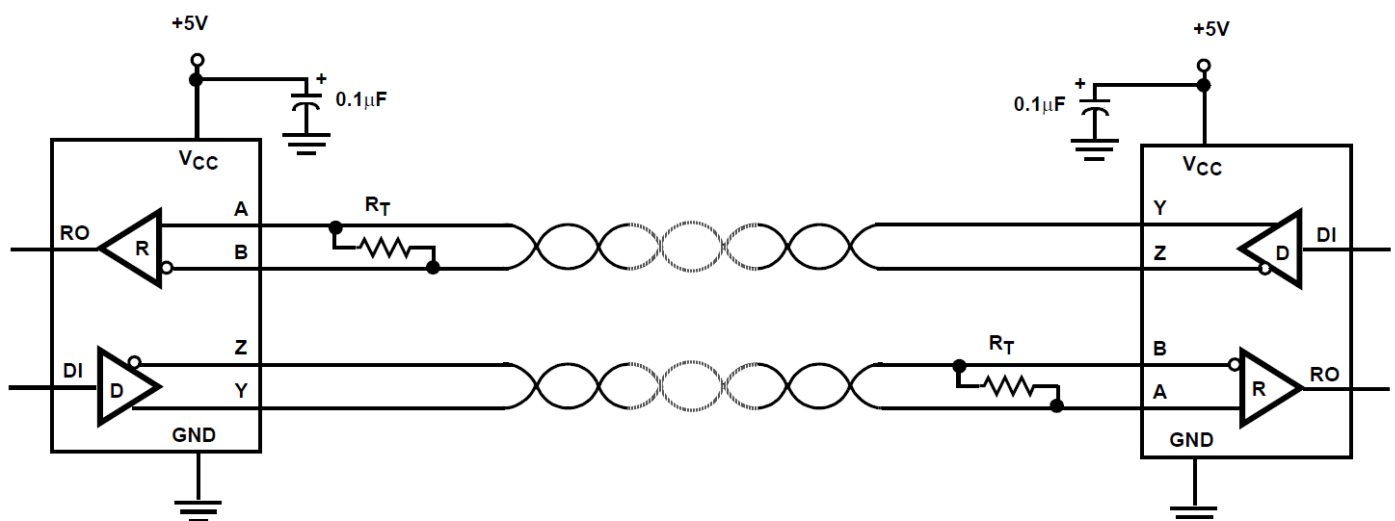

Interface:

Data transfer: SSI Gray-Code

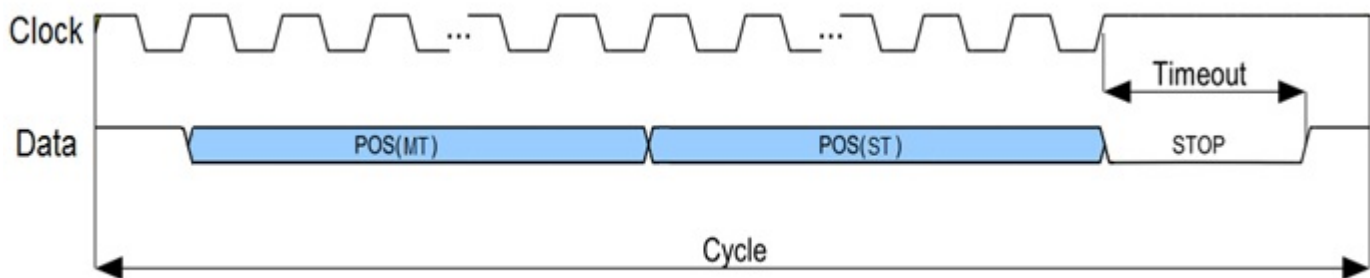

The position data increases when the shaft rotates in the direction of clockwise

Data transfer: BiSS (C-Mode) Binary-Code

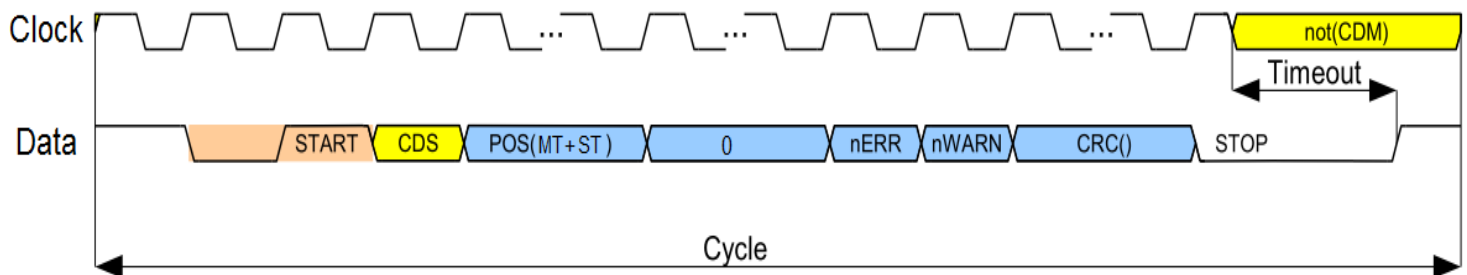

0: These are additional bits to refill the singleturn bit length to 12 bit respectively 16 bit. The number of Zero-bits is depended of the Ordering code (see below). The value of these bits is low.

Example:

Ordering code:	MEM22 - B 09 / 12 -	=>	... + 21 Position bits + 3 x 0 bits + ...
	MEM22 - B 10 / 12 -	=>	... + 22 Position bits + 2 x 0 bits + ...
	MEM22 - B 11 / 12 -	=>	... + 23 Position bits + 1 x 0 bits + ...
	MEM22 - B 12 / 12 -	=>	... + 24 Position bits + ...
	MEM22 - B 13 / 12 -	=>	... + 25 Position bits + 3 x 0 bits + ...
	MEM22 - B 14 / 12 -	=>	... + 26 Position bits + 2 x 0 bits + ...

For a detailed description of the protocol, see separate interface specification.

Error Reset can also executed by command using BiSS interface

Preset and rotation direction are programmable by a BiSS command.

Data transfer: SPI

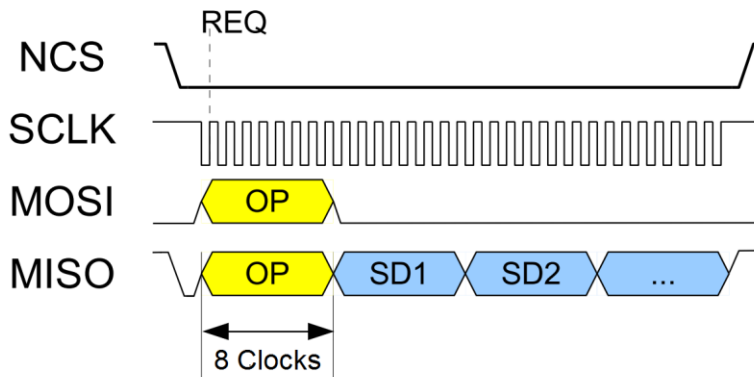

Interface SPI

Connector Pin	Connector Signal	Cable color of wire
1	Backup +	white
2	UB	red
3	GND	blue
4	MISO	pink
5	MOSI	grey
6	NCS	yellow
7	SCLK	green
8	Backup -	brown

Sensor Data Transmission

OPCODEs	
Code	Description
0xB0	ACTIVATE
0xA6	SDAD Transmission
0x9C	Read STATUS

OPCODE Table

Reading Sensor Data: The MEM22 latches the absolute position on the first rising edge at SCLK, when NCS is at zero. Because MEM22 can output the sensor data (SD) immediately, the master can transmit the SDAD Transmission command directly.

The sensor data in SPI are byte aligned. First comes 0-4 byte multiturn depending on the resolution, second are two bytes singleturn and at last one status byte including one error bit, one warning bit and six bits sign-of-life counter.

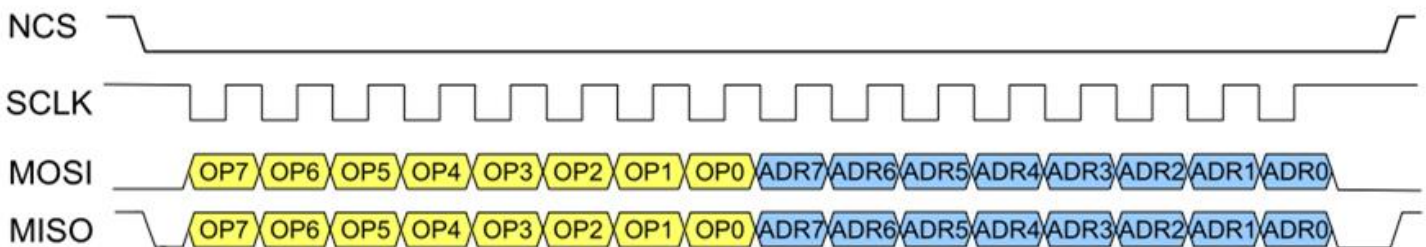

SPI Transmission

Mechanical Notes

Parameter	Value	Tolerance	Unit
Outer dimensions	Ø 22.0 x 21.9	-	mm
Shaft diameter $\varnothing w$	2.0 / 2.5 / 3.0 / 4.0 / 5.0 / 6.0 / 6.35 / 8.0	± 0.01	mm
Required shaft length L_w	9.5	+1.5	mm
Max. allowable axial shaft play of motor	0.2	-	mm
Max. allowable radial shaft play of motor	0.025	-	mm
Mounting screw size (DIN 84)	M1.6	-	-
Tightening torque of the screws	15	-5	Ncm
Pitch circle diameter $\varnothing c$	17.0	± 1.0	mm
Flange bore diameter diameter $\varnothing z$	10.1	+0.03	mm
Mounting boss diameter $\varnothing m$	10.1	-0.03	mm
Max. mounting boss height h_z	1.5	-0.1	mm
Mating connector (Molex)	contact 8x 50079-8000 housing 1x 51021-0800	-	-
Total weight	15	-	g
Moment of inertia of the hub with the magnet	6.0	± 1.0	gmm^2
Protection grade according to DIN 40500	IP50	-	-

Mounting considerations:

The MEM 22 encoder is designed to self align by using a mounting boss. The drawing shows the configuration of the mounting boss along with the location of the mounting screw holes. Shaft diameter and tolerances are given in the above mentioned chart.

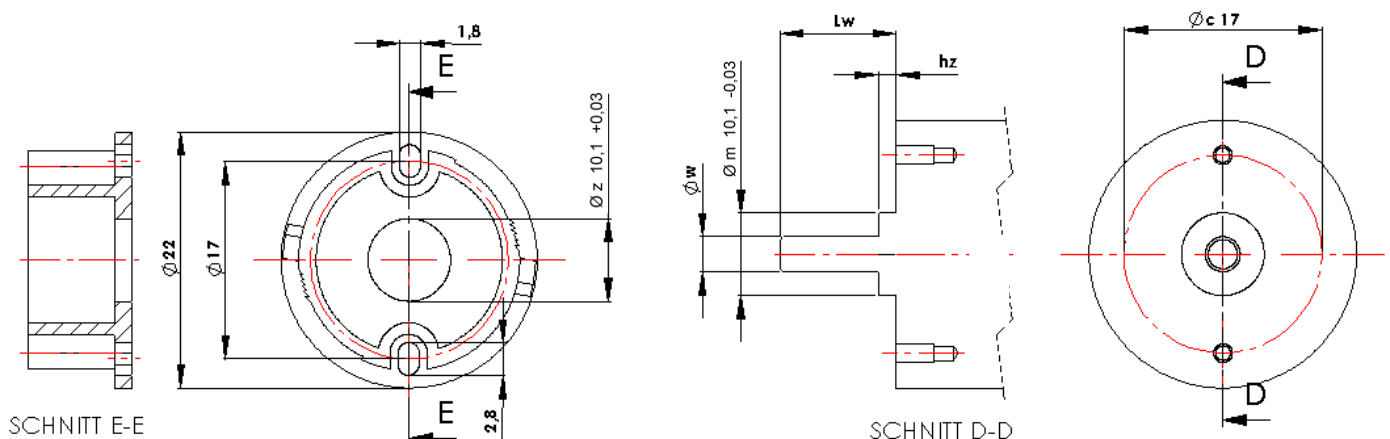

Ordering information

Ordering code:

MEM 22 - X - XX / XX - XX - X - X - XX

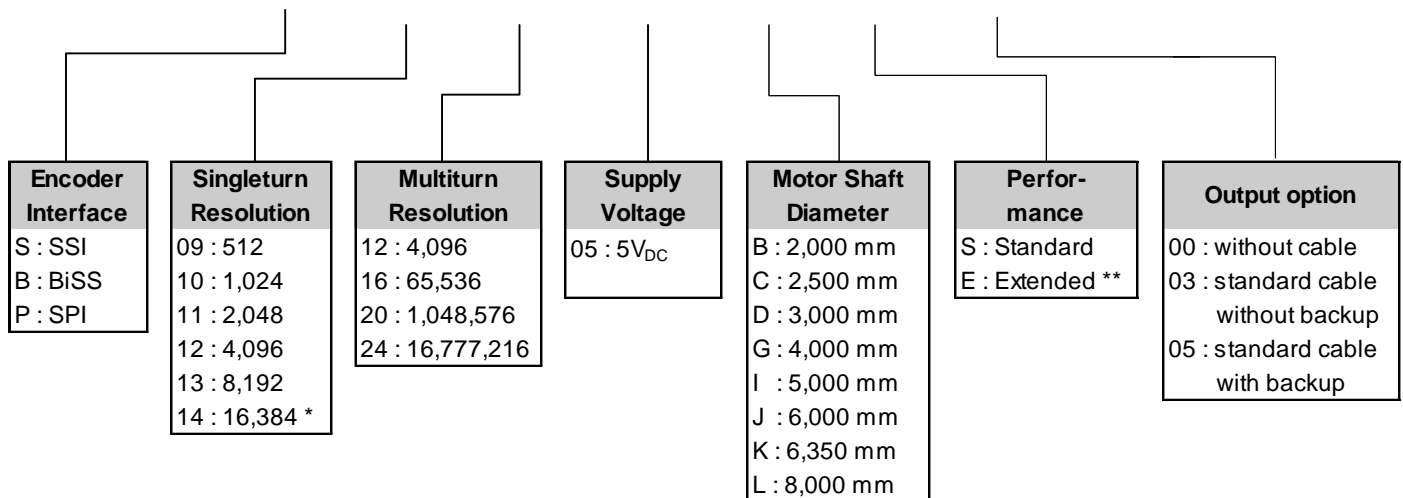

* 14Bit resolution only for BiSS Interface

** customer version



SSI only with gray code
BiSS only with binary code

- Selectable and required accessories see page 12:
- cable 300 mm length (UL1061 / AWG28)
 - cable 500 mm length (shielded, twisted pair)
 - centering and assembly gauge for different motor shafts
 - adapter plates for different motors
 - fastening screws DIN 84 M1.6x3 or M1.6x4

PWB encoders GmbH RESTRICTED

THIS DOCUMENT AND ANY ASSOCIATED DATA CONTAIN RESTRICTED INFORMATION THAT IS PROPERTY OF PWB encoders GmbH AND MAY NOT BE DISCLOSED OR DUPLICATED FOR OTHERS EXCEPT AS AUTHORIZED BY PWB encoders GmbH

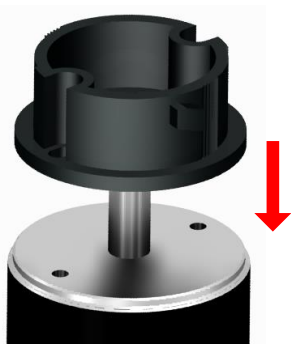
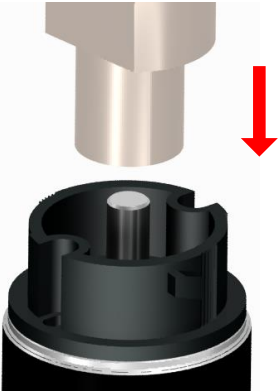
INFORMATION CONTAINED IN THIS PUBLICATION MAY BE SUPERSEDED BY UPDATES. IT IS YOUR RESPONSIBILITY TO ENSURE THAT YOUR APPLICATION MEETS WITH YOUR SPECIFICATIONS.

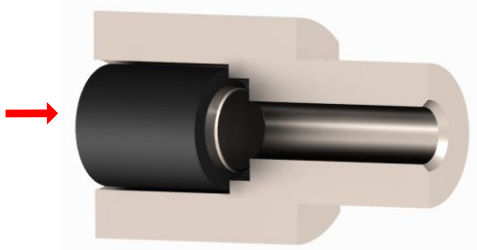
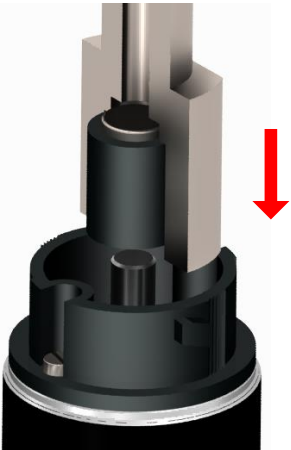
MEM 22 MOUNTING INSTRUCTION	
1	 <p style="text-align: center;">Set the base plate onto the motor</p>
2	 <p style="text-align: center;">Align the base plate to the motor shaft by using the centering gauge</p>
3	 <p style="text-align: center;">Afterwards fix the base plate to the motor flange using two screws</p>
4	 <p style="text-align: center;">Remove the centering gauge</p>
5	 <p style="text-align: center;">Set the hub with magnet into the centering gauge</p>
6	 <p style="text-align: center;">Press the hub with magnet onto the motor shaft by the centering gauge</p>

MEM 22 MOUNTING INSTRUCTION

7

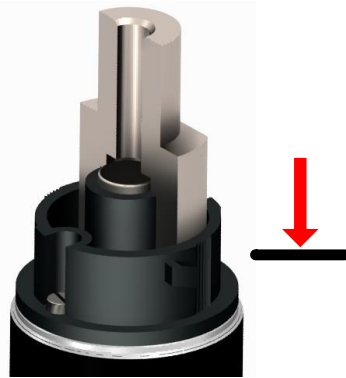

Press the centering gauge down to the final position

8

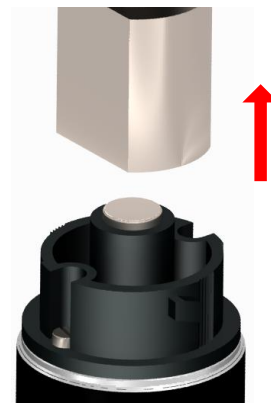

Afterwards remove the centering gauge

9



Align the housing to the base plate, slide the housing onto the base plate

10



Press the housing into the final position

11



Turn the housing into its final position, the encoder is now ready for use

12

WARNING



Do not rotate and pull out the encoder after assembly or when it is in operation.

ATTENTION! The encoder is so designed that it may be assembled only one time, otherwise the guarantee will be voided. Note: see IMPORTANT NOTICE (page 10)

Standard cable with backup

Connection cable 0,14mm²,
shielded, twisted pair

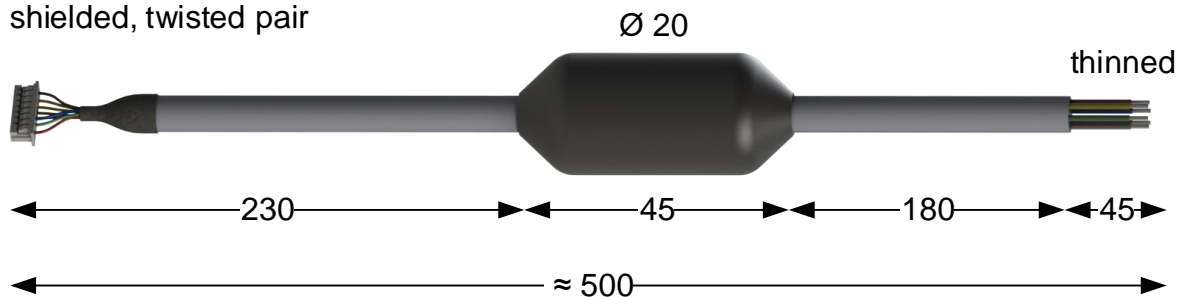

Attention!
Backup battery inside
No liquid permitted

Pin-out description

Cable Signal SSI / BiSS	Cable Signal SPI	Cable color of wire
UB	UB	red
GND	GND	blue
Data +	MISO	pink
Data -	MOSI	grey
Clock +	SCLK	green
Clock -	NCS	yellow

Notification:

For communication with the MEM22 in SSI or BiSS version, a USB converter box is available from PWB encoders. The software can be downloaded from the website.

This can help for the first use and for visualization of the position data. It is not necessary for operation in the customer application with the customer control.

ESD Warning: Normal handling precautions should be taken to avoid static discharge damage to the sensor.

Essential assembly tool

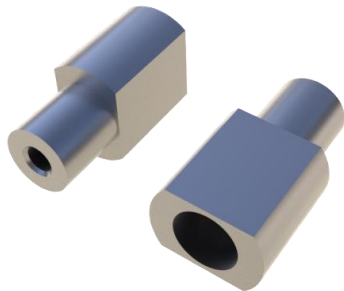

Centering and assembly gauge for centering the base plate on the motor flange or an adapter plate and also positioning the magnet

Available accessories



Customized adapter plate

Available accessories *

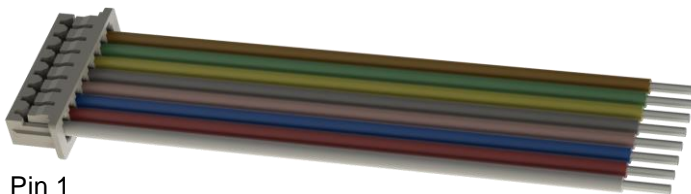

Pin 1

Cable without backup (length 300 mm)
[for applications with backup on customer control]

* Note: see ordering code 03



Screws DIN84 M1.6 X 3 or M1.6 X 4

IMPORTANT NOTICE

The encoder is so designed that it may be assembled only one time, otherwise the guarantee will be voided.

The guarantee will be voided by misuse, accident, modification, unsuitable physical or operating environment, operation in other than the specified operating environment, or failure caused by a product for which **PWB encoders GmbH** is not responsible.

PWB encoders GmbH reserves the right to make corrections, modifications, enhancements, improvements, and other changes to its products and services also datasheets at any time.