

“Smart Battery Charger” CB Series: CB1224xA/CB1224xAJ

Thank you for having chosen one of our products for your work.
We are certain that it will give the utmost satisfaction and be a notable help on the job.



General Description

The CB series is a “Switching technology” and “Battery Care philosophy” since many years parts of the know-how ADEL system, led to the development of this advanced multi-stage battery charging, completely automatic and suited to meet the most advanced requirements of battery manufacturers. The Battery Care concept is based on algorithms that implement rapid and automatic cycle of battery charging, battery charge optimization during time, flat batteries recovery and real time diagnostic during installation and operation. The Real Time Auto-diagnostic system, monitoring battery faults such as, elements in short circuit, accidental reverse polarity connection, disconnection of the battery, they can easily be detected and removed by help of Blink Code of Diagnosis Led; during the installation and after sell. Each device is suited for all

battery types, jumper selection sets a predefined curves for: Open Lead Acid, Sealed Lead Acid, Gel, Ni-Cd and Ni-Mh. A rugged casing with bracket for DIN rail mounting provide IP20 protection degree. Only for CB1224xAJ it is available the CAN output, according to the J1939 protocol to connect the device to other electronic units.

Main Characteristics

- Input: Single-phase 115 – 230 – 277 Vac
- Output Battery: 24 Vdc 5 A; 12 Vdc 6 A
- CAN output according to the J1939 (only CB1224xAJ model)
- Suited for the following battery types: Open Lead Acid, Sealed Lead Acid, lead Gel and Ni-Cd.
- Automatic diagnostic of battery status. Charging curve IUoUo, constant voltage and constant current Battery Life Test function (Battery Care)
- Switching technology
- Four charging levels: Boost, Absorption, Trickle and Recovery
- Protected against short circuit, Over Load and inverted polarity
- Signal output (contact free) for discharged or damaged battery
- Protection degree IP20 - DIN rail; Space saving

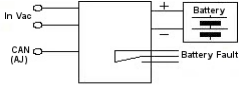

Safety and warning notes

WARNING – Explosion Hazard Do not disconnect Equipment unless power has been switched off or the area is known to be non-hazardous.
WARNING – Explosion Hazard. Substitution of components may impair suitability for class I, Division 2.
WARNING – Switch off the system before connecting the module. Never work on the machine when it is live. The device must be installed in according to UL508. The device must have a suitable isolating facility outside the power supply unit, via which can be switched to idle. Danger of fatal Injury!

Connection (terminal and wiring):

Cable Connection: The following cable cross-sections may be used:

In:	Solid (mm ²)	Stranded (mm ²)	AWG	Torque (Nm)	Stripping Length	1 Phase L N PE Input AC	1 Phase L N PE Input AC
0.2 – 2.5	0.2 – 2.5	24 – 14	0.5 – 0.6 Nm	7 mm			
Out:	0.2 – 2.5	0.2 – 2.5	24 – 14	0.5 – 0.6 Nm	7 mm		
Signal:	0.2 – 2.5	0.2 – 2.5	24 – 14	0.5 – 0.6 Nm	7 mm		
CANBUS L	0.2 – 1.5	0.2 – 1.5	24 – 16	0.25 Nm	7 mm		
CANBUS H	0.2 – 1.5	0.2 – 1.5	24 – 16	0.25 Nm	7 mm		

Use only copper cables that are designed for operating temperatures of > 75 °C. Wiring terminal shall be marked to indicate the proper connection for the power supply.

No. 3: Signal Ports (output Isolated):

Connections for Fault Alarm Relay: Low Battery, Fault connections systems, Battery replacement. Contact: 3,4,5
Relay Contact Rating:
Max.DC1: 30 Vdc 1A; AC1: 60 Vac 1A: Resistive load (EN 60947-4-1)
Min.1mA at 5Vdc: Min. permissive load

Signal Output port true table:	Led N°8 Battery Fault	
	3-4 Closed	3-5 Closed
Battery or system Fault?	YES	NO
	led off	led On

NOTE: (*) In Recovery the LED Battery Fault (No.8) is OFF but the Relay is in failure mode (3-5 Closed) to indicate a battery with very low voltage.

No. 4: Battery Connection Port:

Connect the battery between pin. 1 (+) and 2 (-).
One battery 12 V for 12 Vdc Output;
Two battery 12 V for 24 Vdc Output;

No. 5: Output Voltage Configuration

The device can work at 12Vdc or at 24Vdc setting a jumper. This setting must be do with mains off. This jumper set the voltage of the batteries connected at the CB, is most important to check the correct voltage value on the batteries. If is connected a wrong battery the device show the fault indication of 1 blink.

No. 6: Enable Power Supply

This function allow the Battery Charger to function like a Power Supply. To enable this function the operator must insert a jumper in Pos. 6 Enable Power Supply with the CB unpowered. When the device is turned ON we will have voltage to the output terminals OUTPUT BATTERY even if the battery is not present. After about 10 sec. without detecting a battery, the CB signals with 2 blink the status of “Battery Not Connected” and switches the alarm relay. If the battery was already present at power on or if it is connected at a later time, the CB detects the battery and starts to charge. If there is no fault deactivates, the alarm relay and the LED DIAGNOSIS indicate the charging status. In Back Up (no Mains) and cell voltage < 2.18V (Pb batteries) or < 1.37V (NiCd batteries) for more than 30 sec. the system turns off completely.

No. 7 and 8 Display Signals

No.8: Led Battery Fault connections systems, Battery Fault
No.7: Led Diagnosis. Diagnosis of the system through “blinking code” signal

Monitoring Control Chart:	State	LED Diagnosis (No.7)	LED Battery Fault (No.8)	
Charging Type	Float	1 Blink/ 2 sec	OFF	
	Absorption	1 Blink/sec	OFF	
	Bulk	2 Blink/sec	OFF	
	Recovery (*)	5 Blink/sec	OFF	
Auto diagnosis of the system	Reverse polarity or wrong battery voltage (for example: CB set for 24Vdc and battery 12Vdc)	1 Blink/pause	ON	
	Battery Not connected	2 Blink/pause	ON	
	Element in Short Circuit	3 Blink/pause	ON	
	Over Load or Short Circuit on the load (with Enable Power Supply)	4 Blink/pause	ON	
	Alarm Low Battery Voltage: ONLY on REQUEST	12Vdc, range 8-10 Vdc 24Vdc, range 18-21 Vdc	9 Blink/pause	ON
	Alarm High Battery Voltage: ONLY on REQUEST	12Vdc, over 14 Vdc 24Vdc, over 28 Vdc	10 Blink/pause	ON

NOTE: (*) In Recovery the LED Battery Fault (No.8) is OFF but the Relays is in failure mode (3-5 Closed) to indicate a battery with very low voltage.

Output Power connections:

Normal connection

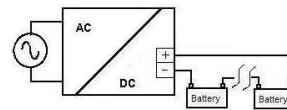

Typical application:
- One battery (12Vdc) for 12 Vdc Output
Set No Jumper in Pos.5
- Two battery (12Vdc) for 24 Vdc Output
Set Jumper in Pos. 5 (See the table below at the point No. 2.)

Operating and Display Element:

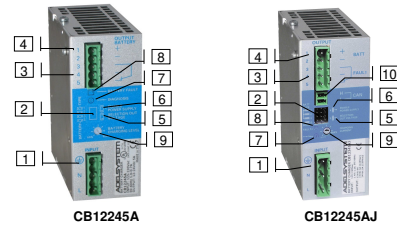

No. 1: Input AC Port pin. L – N:

1 Phase Switching Power Supplies L, N, PE @.

No. 2: Battery Management Configurations

Preliminary Operations: One device for all battery types.
Completely automatic, all devices are suitable to charge most batteries types thank to User Selectable charging curves. They can charge open lead acid, sealed lead acid, Gel and Ni-Cd batteries. It is possible to change or add other charging curves connecting the device to a portable PC.
Caution: Switch off the system before setting the jumper.

Battery Type Selection	Jumper Position	Trickle/Float charge (Volt/Cell)	Fast/Bulk charge (Volt/Cell)
Open Lead	1 0 0 0 2 0 0 0 3 0 0 0 4 0 0 0	2.23	2.40
Sealed Lead Low	1 0 0 0 2 0 0 0 3 0 0 0 4 0 0 0	2.25	2.40
Gel Battery	1 0 0 0 2 0 0 0 3 0 0 0 4 0 0 0	2.30	2.40
NiCd – NiMh	1 0 0 0 2 0 0 0 3 0 0 0 4 0 0 0	1.40 – (12V) 10cells 1.40 – (24V) 20cells	1.50 – (12V) 10cells 1.50 – (24V) 20cells
Functional Setting		Function	
Jumper Fast Charge Enable	1 0 0 0 2 0 0 0 3 0 0 0 4 0 0 0	Jumper present: Fast charge enabled. This function is a hot swap (is possible to enable or disable with mains on).	
Output Voltage Configuration (Pos. 5)	1 0 0 0 2 0 0 0 3 0 0 0 4 0 0 0	5	Jumper Not Present: 12 V Output Jumper present: 24 V Output
Power Supply Function (Pos. 6)	1 0 0 0 2 0 0 0 3 0 0 0 4 0 0 0	6	Jumper Present: Power supply function enabled.

No. 9: Charging Level Current:

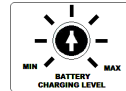

It is possible set the max recharging current for the batteries by trimmer (Charging Level). The current adjustment goes from 10% + 100% of In. Set the maximum charging current between 10% and 20% of the battery capacity.

No. 10: CAN output:

CAN protocol is defined as the set of rules transmitting and receiving messages in a network of electronic devices, in particular it is possible to connect the CB1224xAJ to Adelsystem manager display DPY351. The CAN bus has a big capacity to identify errors, the probability which a message is wrong is almost none. This because the CAN bus is based on two lines weaved, called H and L (high and low) and it works in differential mode between the two lines so the noise is cancelled. There are different protocols based on CAN bus, Adelsystem uses the SAE J1939 protocol. To active this function connect the CAN output to the clamp.

Charging Curve

Automatic multi-stage operation and real time diagnostic allows fast recharge and recovery of deep discharged batteries, adding value and reliability to the system hosting the CB device. The type of charging is Voltages stabilized and Current stabilized IUoUo.
Four charging modes are identified by a flashing code on a Diagnosis LED.
To maintain the Output Load in lower Voltage state, do not put jumper in position 4, in this case no boost charge but only Trickle charge.

Charging Type	State	Diagnosis LED	Battery Fault LED	Time for CB1224xA	Time for CB1224xAJ
	Trickle	1 Blink/ 2sec	OFF		
Absorption	1 Blink/sec	OFF		5h max	4h max (8h for NiCd)
Bulk	2 Blink/sec	OFF		15h max (8 for NiCd)	15h max
Recovery	5 Blink/sec	OFF		60sec	240h max

CB1224xA - CB1224xAJ Charging Diagram

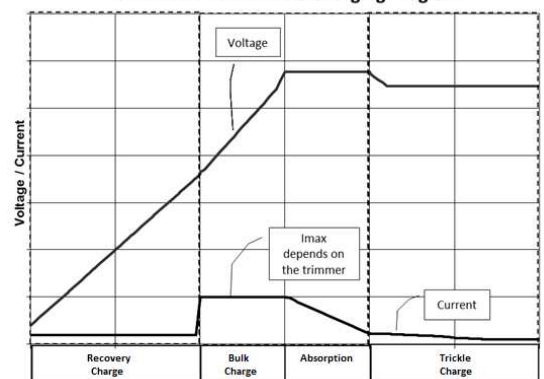

Battery Care

The Battery Care philosophy is base on algorithms that implement rapid and automatic charging, battery charge optimization during time, flat batteries recovery and real time diagnostic during installation and operation. The Real Time Auto-diagnostic system, monitoring battery faults such as, elements in short circuit, accidental reverse polarity connection, disconnection of the battery, they can easily be detected and removed by help of Blink Code of Diagnosis Led; during the installation and after sell. Each device is suited for all battery types, by means of jumpers it is possible

setting predefined curves for Open Lead Acid, Sealed Lead Acid, Gel, Ni-Cd (option). They guarantee battery reliability in time by continuously testing the internal impedance status, avoids any possible risk of damages and grants also a permanent, reliable and safe connection of the battery to the power supply. The system, through a battery stimulation circuit with algorithms of evaluation of the detected parameter, is able to recognize batteries with a short-circuited element. Battery test: Automatic.

Every time a battery will be connected to the Battery Charger, the device will do followings check: reverse battery polarity, wrong battery connected (like batteries 24 – 36Vdc or higher) with Jumper n.5 not present = Battery charger for 12Vdc. After 120 minutes, with jumper in pos. 5 present (24 Vdc output configuration) the device make the test of wrong battery connected like batteries 12Vdc. Every 240 minutes, make the test element in short circuit.

Diagnostic Type Checks:

Check for accidental disconnection of the battery cables

The device detects accidental disconnection and immediately switched off the output power.

Battery not connected

If the battery is not connected no output power.

Reverse Polarity check

If the battery it is connected with inverted polarity, the device is automatically protected.

Test of battery voltage connections

Appropriate voltage check, to prevent connection of wrong battery types, more or less than the nominal voltage.

End of Charge check

When the battery it is completely full, the device automatically switch in trickle charging mode.

Check for Battery Cells in short circuit

Thanks to specific algorithms of evaluation, the CBs recognize batteries with cells in internal short circuit.

In trickle charge every 4 hours test of element in short circuit.

Diagnosis of battery and device

All CB devices support the user during installation and operation. A Blink code of Diagnosis Led allows to discriminate among various possible faults.

Error conditions, "LED Battery Fault" ON and "LED Diagnosis" blinking with sequence; see Display Signal section.

Protection Features

On the primary side

The device is equipped whit an internally fuse. If the internal fuse is activated, it is most probable that there is a fault in the device. If happen, the device must be checked in the factory.

On the secondary side Battery and load

The device is electrically protected against short circuits and overload.

Inversion polarity

The module it is automatically protected against inversion of battery polarity and connection of load inverted.

Over current and output short circuit

The unit limits the output current (see the technical data).

Thermal behaviour

Surrounding air temperature 50°C. For ambient temperature of over 50°C, the output current must be reduced by 2.5% per °C. Max 70°C At the temperature of 70°C the output current will be 50% of In. The equipment does not switch off in case of ambient temperature above 70°C or thermal overload. The devices are protected for Over temperature conditions "worst case"; in this situations the device Shut-down the output and automatic restart when temperature inside fall.

Standards and Certification

Electrical Safety:

Assembling device: IEC/EN 60950 (VDE 0805) and EN 50178 (VDE 0160).

Installation according : IEC/EN 60950.

Input / Output separation : SELV EN 60950-1 and PELV EN 60204-1. Double or reinforced insulation.

EMC Standards Immunity:

EN 61000-4-2, EN 61000-4-3, EN 61000-4-4, EN 61000-4-5.

EMC Standards Emission:

EN 61000-6-4, EN 61000-6-3, EN 61000-3-2 (see data sheet for each device)

Standards Conformity:

Safety of Electrical Equipment Machines: EN 60204-1.

CE The CE mark in According to EMC 2004/108/EC and Low voltage directive 2006/95/EEC

UL In According to UL 1236 and CSA C22.2 N° 107.2

Norms and Certifications

In Conformity to: UL1236, IEC/EN 60335-2-29 Battery chargers; EN60950 / UL1950; Electrical safety EN54-4 Fire Detection and fire alarm systems; 2014/30/UE Directive; 2014/35/UE (Low Voltage); DIN41773 (Charging cycle); Emission: IEC 61000-6-4; Immunity: IEC 61000-6-2. CE.

Rail Mounting:



All modules must have a minimum vertical and horizontal distance of 5 mm to this power supply in order to guarantee sufficient auto convection. Depending on the ambient temperature and load of the device, the temperature of the housing can become very high!

Mounting Steps: 1, 2, 3, 4.

Removing Steps: 4, 3, 2, 1.

MOUNTING – REMOVING

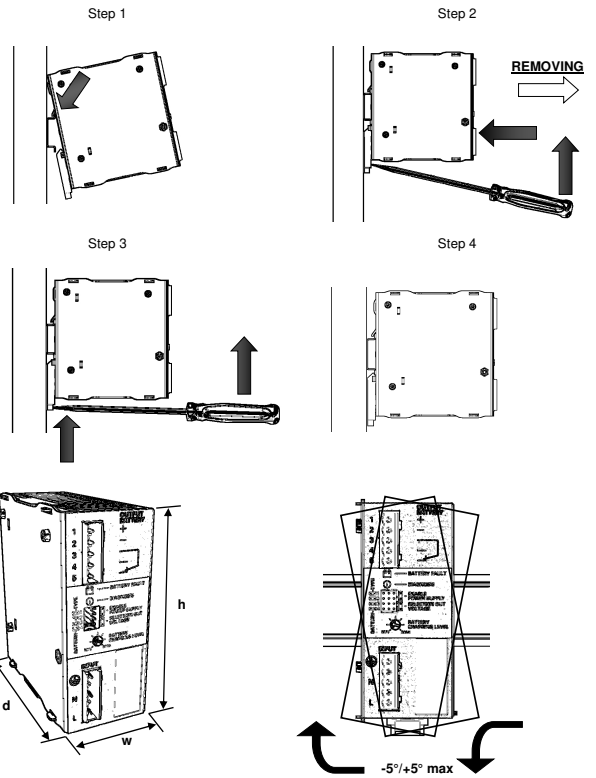

Technical data

	CB12245A	CB12245AJ
Input Data		
Nominal Input Voltage (2 x Vac)	115 – 230 – 277	115 – 230 – 277
Input Voltage range (Vac)	90 – 305	90 – 305
Inrush Current (Vn and In Load) I _r	≤ 16 A ≤ 5 msec.	≤ 16 A ≤ 5 msec.
Frequency	47 – 63 Hz ±6%	47 – 63 Hz ±6%
Input Current (115 – 270 Vac)	2.4 – 1.2 A	2.4 – 1.2 A
Internal Fuse	4 A	4 A
External Fuse (recommended)	10 A (MCB curve B)	10 A (MCB curve B)
Battery Charger Output 24 Vdc (depend on jumper selection)		
Fast Charge - Boost Charge (Lead Acid)	28.8 Vdc	28.8 Vdc
Fast Charge - Boost Charge (Ni-Cd)	30 Vdc	30 Vdc
Recovery Charge	6 – 18 Vdc	6 – 18 Vdc
Charging Current Max I _{bat} < 40°C(In) Input V. 230Vac	5 A ± 5%	5 A ± 5%
Charging Current Max I _{bat} < 40°C(In) Input V. 120Vac	4 A ± 5%	4 A ± 5%
Charging Current Max I _{bat} > 40°C(In)	3.5 A ± 5%	3.5 A ± 5%
Battery Charger Output 12 Vdc (depend on jumper selection)		
Fast Charge - Boost Charge	14.4 Vdc	14.4 Vdc
Fast Charge - Boost Charge (Ni-Cd)	15 Vdc	15 Vdc
Recovery Charge	3 – 8 Vdc	3 – 8 Vdc
Charging Current Max I _{bat} < 40°C (In)	6 A ± 5%	6 A ± 5%
Charging Current Max I _{bat} > 40°C (In)	6 A ± 5%	6 A ± 5%
Battery Tester		
Short circuit Element Detection	Yes	Yes
Battery Impedency (Life test)	No	No
Reverse polarity protection	Yes	Yes
Battery Disconnected (Protection No Spark)	Yes	Yes
Battery Voltage Wrong	Yes	Yes
End of charge control	Yes	Yes
Generic Output Data		
Max. time Bust Charge (typ. At In)	15 h	15 h
Min. time Bust Charge (typ. At In)	4 min.	4 min.
Max.Time Bulk charge (Typ. at IN)	15 h	15 h
Min.Time Bulk charge (Typ. at IN)	4 min.	4 min.
Trickle Charge: Depend on Battery type	2.23;2.25;2.27;2.3	2.23;2.25;2.27;2.3
Trickle Charge Ni-Cd: V/cell (Jumper Config Battery type)	1.4 V	1.4 V
End of charging current (Bulk & Absorption charge)	6% charging current	6% charging current
Charging current limiting I _{bat}	20 ± 100 % / I _n	20 ± 100 % / I _n
Quiescent Current	≤5mA	≤5mA
Remote Charge Input Control	Bulk / Trickle	Bulk / Trickle
Power Supply function	By Jumper Enabling	By Jumper Enabling
Output Voltage 12 or 24 Vdc Selection	By Jumper Enabling	By Jumper Enabling
Boost charge Enabling	By Jumper Enabling	By Jumper Enabling
Efficiency (50% of In)	90%	90%
Dissipation Power load max (W)	9	9
Residual Ripple	≤ 60 mVpp	≤ 60 mVpp
Quiescent Current	≤ 5 mA	≤ 5 mA
Charging Curve automatic: I _{uo} U _o	4 stage	4 stage
Detection of element in short circuit	Yes	Yes
Short-circuit protection)	Yes	Yes
Over Load protection	Yes	Yes
Overheating Thermal Protection	Yes	Yes
Over Voltage Output protection	(Typ. 35Vdc)	(Typ. 35Vdc)
Connection and Monitoring		
Signal Output (free switch contact)		
Main or Backup Input Power	Yes	Yes
Low Battery	Yes	Yes
Fault Battery	Yes	Yes

Type of Signal Output Contact (free switch contact)		
Max. current can be switched (EN60947.4.1):		
Max. DC1: 30 Vdc 1 A; AC1: 60 Vac 1 A	Resistive load	Resistive load
Min. 1mA at 5 Vdc	Min. load	Min. load
Can (connection)		
CanBus J1939	No	Yes
General Data		
Insulation voltage (In / Out)	3000 Vac	3000 Vac
Insulation voltage (In / PE)	1605 Vac	1605 Vac
Insulation voltage (Out / PE)	500 Vac	500 Vac
Protection Class (EN/IEC 60529)	IP20	IP20
Protection class	I, with PE connected	I, with PE connected
Reliability: MTBF IEC 61709	> 300.000 h	> 300.000 h
Pollution Degree Environment	2	2
Connection Terminal Blocks screw Type	2.5mm(24–14AWG)	2.5mm(24–14AWG)
Dimensions (w-h-d)	45x110x105 mm	45x110x105 mm
Weight	0.30 Kg approx.	0.30 Kg approx.
Safety Standard Approval	CE – UL1236	CE
Climatic Data		
Ambient temperature (operation)	-25 ± +70°C	-25 ± +70°C
De Rating T ₁ > 50°C	-2.5%(In) / °C	-2.5%(In) / °C
Ambient temperature Storage	-40 ± +85°C	-40 ± +85°C
Humidity at 25 °C no condensation	95% to 25°C	95% to 25°C
Cooling	Auto Convection	Auto Convection
Auto Derating	Yes Up to 50 °C	Yes Up to 50 °C
Accessory		
ADELView Graphic		
ADELView System		