

HOG 86

The incremental *HeavyDuty* encoder
for highest demands





Extremely robust.

Failsafe in any environment

The solid, extremely sturdy housing with minimum 10 mm wall thickness is a prerequisite design benefit in reliable encoder operation. Special anti-corrosion coating ensures seawater resistance in compliance with C4 protection. Additional encapsulation will keep the electronics safe against dirt, soiling and humidity even while the connection cover is opened for installation.

Protected against bearing damages

Insulated bearings or optional hybrid bearings safely compensate inductive shaft currents and prevent the electronics from damage by voltage impacts up to 2,5 kV. Hybrid bearings excel by their outstanding service life of 100 000 hours.

Safe at extreme temperatures

The encoder reliably endures temperatures from -40 to +100 °C in long-term operation.

Capable of high shaft loads

Large, high-quality dual ball bearings compensate high radial and axial shaft loads and will ensure ultimate longevity thanks to their high load reserve potential.

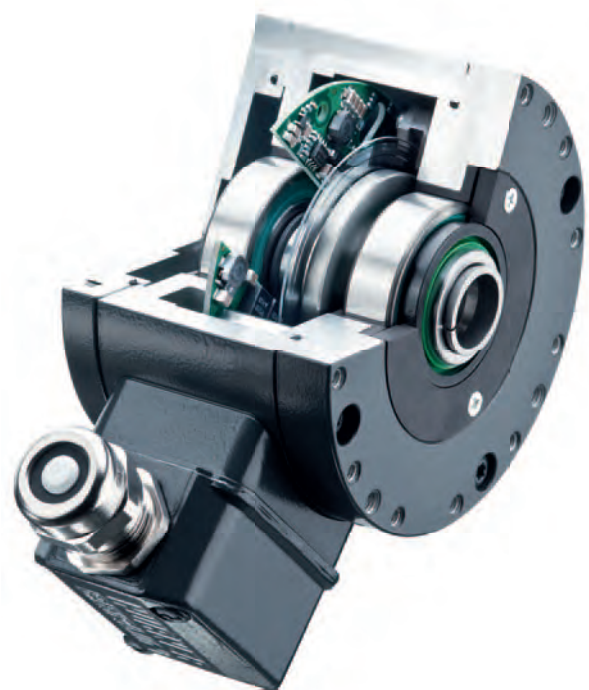

Defying any environment

Specialised housing encapsulation and shaft seals enable longterm IP 66 protection and will reliably prevent the encoder from damage caused by penetration of dust, dirt or liquids.

Safe and precise.

Quick installation, less downtime

The optional Enhanced Monitoring System (EMS) monitors vital encoder functionalities throughout the entire speed range, eases error tracing and significantly cuts down expensive downtime. The multicolor LED provided at the encoder signals proper encoder supply and output driver operation as well as encoder signal integrity. The error output reports the encoder activity status. The EMS monitoring functionality will signal connection errors right away during installation and reduce commissioning times.

Perfect signal quality

High-performance, resilient output drivers ensure top signal quality over 500 m (TTL) respectively 300 m (HTL) cable routing.

Proven sensing technique

The interference-immune optical sensing technology by highly integrated OptoASIC defies major temperature fluctuations and harsh ambient conditions for consistently high signal quality and precise measuring results.



Safe, highly available signal transmission

Products with fiber optic output are ideal when it comes to reliable signal transmission up to 1500 m distance - especially in environments with electromagnetic interference.

- Encoder with outdoor-capable fiber optic output
- Absolutely reliable signal transmission and quality by two redundant fiber optic outputs
- Long-distance transmission at minimized wiring effort
- Reduced installation work
- The ideal solution in metal and steel processing, at cranes and lifting platforms, in wind turbines or very spacious systems

HOG 86 M – redundant signals for ultimate safety and availability

Two-channel detection of relative position or rotation speed using two independent signal outputs will immediately identify any machine or system error. HOG 86 M hosts two sensing systems which are fully independent from each other.

As an option, redundant EMS functionality will additionally monitor the two sensing systems which makes HOG 86 M the product of first choice in safety-relevant applications.

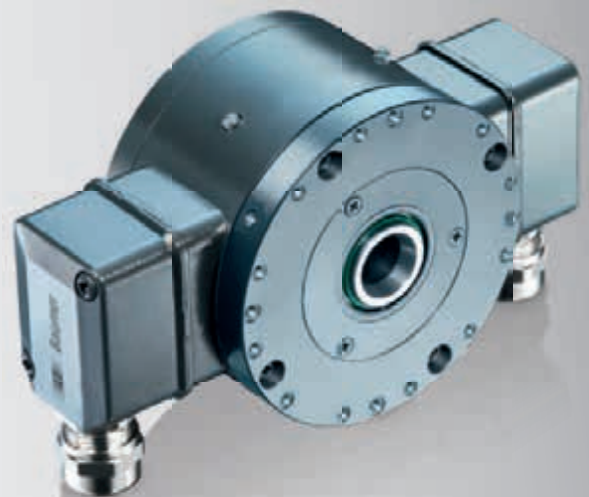



Optimally installed.

Four mounting holes provided at front and rear allow for installation right with the torque plate which can be attached to the front in up to 12 different angular positions.

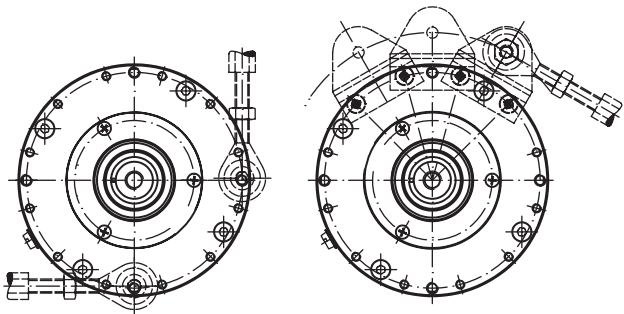

Choose the connection for the perfect match:

- Radial terminal box
- Flange connector
- Cable outlet
- Fiber optic output

Easy, quick and safe connection by *HeavyDuty* terminal box

- Eased installation by preassembled cable
- On-site modifications not required
- Cable outlet rotatable through 180°
- Optimum cable routing in any installation position
- Perfect and longterm safe connection



Terminal box rotatable through 180°



HOG 86 – the *HeavyDuty* encoder with reserve capacity.

Harsh ambient conditions like in steel plants, at gantry cranes or vertical lift bridges demand the most of the deployed encoders. The high mechanical reserve potential will ensure reliable operation. New encoder HOG 86 by Baumer Hübner, previously Hübner Berlin, is an encoder platform to meet even the highest demands

- thanks to more than 50 years of expertise as market leader in *HeavyDuty* technology. Unrivalled in robustness and product variety, you will always encounter the encoder that is the perfect match for your application.

Your benefits at a glance:

- Extremely robust
- Quickly installed
- Reliable and precise



Robust design



Dual bearings



Insulated bearings



Interference-immune sensing by OptoASIC



High-quality seals IP 66



Fiber optic interface



High temperatures



Cold climate

HOG 86 product overview.



HOG 86 ML



HOG 86 F



HOG 86 T

	HOG 86 T	HOG 86 F	HOG 86 K	HOG 86 M	HOG 86 L	HOG 86 ML
Sensing method	Optical					
Voltage supply and output circuit	5 VDC \pm 5 %, TTL/RS422, max. 500 m 9 ... 30 VDC, TTL/RS422, max. 500 m 9 ... 30 VDC, HTL/push pull, max. 300 m			9 ... 30 VDC, LWL1, LWL2 redundant, max. 1500 m		9 ... 30 VDC, LWL1, LWL2 redundant, max. 1500 m 9 ... 30 VDC, TTL/RS422, max. 500 m 9 ... 30 VDC, HTL/push pull, max. 300 m
Output signals	K1, K2, K0 and inverted / Error output (only with EMS)					
Shaft	Non-through hollow shaft, \varnothing 12 mm or 16 mm Cone shaft 1:10, \varnothing 17 mm / Shaft material: stainless steel					
Connection	Terminal box rotatable through 180°	M23-connector outlet	Cable outlet	2 x terminal box (redundant sensing and signal output)	Terminal box with fiber-optic interface	Terminal box with 2 redundant fiber optic outputs and terminal box rotatable through 180° for HTL/TTL signal
Pulses per revolution	500 ... 2500					
Operating temperature	-40 ... +100 °C		-40 ... +80 °C	-40 ... +100 °C		-20 ... +70 °C
Operating speed	\leq 10000 (mechanical)					
Protection class	IP 66					
Insulated bearings / hybrid bearings as an option	•/•	•/•	•/•	-/•	•/•	-/•
EMS	Optional					
Approvals	CE, UL, CSA				CE, UL	
Ex protection	II3G Ex nA T4 X (gas), II3D Ex tD IP 66 A22 T135 °C (dust)					

More product information on our *HeavyDuty* encoders is available for download under www.baumer.com/HOG86 or will be gladly provided by our encoder experts. Contact us.

Find your local partner: www.baumer.com/worldwide

 **Baumer**
Passion for Sensors

Baumer Group
International Sales
P.O. Box · Hummelstrasse 17 · 8501 Frauenfeld
Phone +41 52 728 1122 · Fax +41 52 728 1144
sales@baumer.com · www.baumer.com