

Issue 2011

High-performance Light Barrier



pantron
sensor technology

Description	
High-performance Light Barrier	3
Applications	3
Compendium	4
Sensor	
Technical Data	6
Range overview	6
Purchase order table	7
Dimension drawing	8
Connection diagram	9
Accessories	
Connection cable	10
Glass fiber optic cable	10
Protective glass shield / light shutter	10
Sensor mounting bracket	10
Sensor cleaner	10
Amplifier	
Product overview	12
ISM-Series	
1-channel amplifier	13-17
2-channel amplifier	18
4-channel amplifier	19
8-channel amplifier	20
ISG-Series	
1-channel amplifier	21-29
1-channel automatic-amplifier	30-35
IMX-Series	
2-channel amplifier	36-39
4-channel amplifier	40
8-channel amplifier	41
2-channel automatic-amplifier	42
8-channel automatic-amplifier	43
Accessories	
Protective enclosure	44-45
Power supply unit	46
DIN-socket/ retaining clip	47
Measurement cable / communication cable	47

Sensor

Amplifier

 All Pantron products fulfil the following approvals:    **Safety instructions:** The devices are not to be used for applications where personal safety is dependent on their function.

All technical specifications refer to the state of art 02/2011. Subject to modifications.

High-performance Light Barrier

Pantron devices are internationally successful state-of-the-art products made in Germany.

The high-performance light barriers were specially developed for areas of application in which traditional photo-electric sensors reach their limits. Extreme dirt resistance and a long range make them particularly suitable for most difficult applications. The system's high power guarantees excellent penetration, even in the case of extreme contamination. Chips, dust, flour, oil or muddy water are no longer an obstacle. They are perfectly suitable for use in the timber and paper industry, in car wash systems, for control bulk material, in elevators, for outdoor gate control, in the food processing industry and in many other applications.

Each system consists of a transmitter, a receiver and an amplifier. Transmitter and receiver are available in different, highly compact designs so they can be installed in any applications. Thanks to their large field of view, they can be easily aligned even at distances of 70 meters. Simultaneously they are insensitive to shock and vibrations and the resolution of the misalignment.

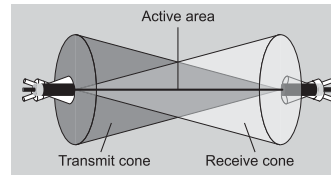

The simple installation of the amplifiers and sensors as well as the uncomplicated handling of the devices emphasize the high user friendliness.

Amplifiers are available in different variations, starting with the base unit, a manual amplifier that adjusts with a potentiometer. Also available is a patented automatic amplifier with automatic adjustment to disturbing influences. For applications where multiple sets of sensors are needed, a fast 8-channel multiplex-amplifier is available. With this wide range of products, no application is impossible.

The sensors can be mounted according to different operating principles as required:

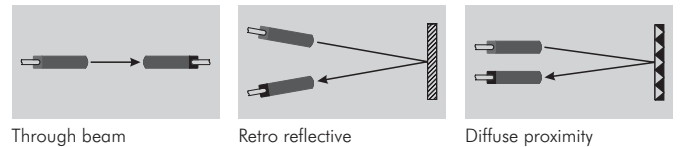

Applications

Through beam light barrier

- Harsh and dirty to control the levels of bulk material in silos.
- Gate control in industrial sectional gates, also outdoor in rain, snow and fog.
- Door control in passenger and industrial elevators.
- Extremely dusty environments, such as cement or gravel plants.

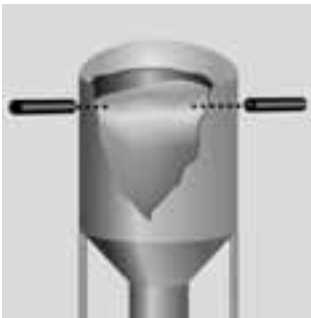

Multi-channel light barrier

- High humidity, with a high condensation of water and drizzle on the optical system, as in vehicle wash systems.

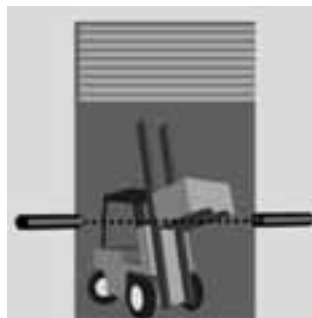

Light curtain

- Multiplex amplifiers in an extremely dirty environment, as in measuring the thickness of tree trunks in sawmills.

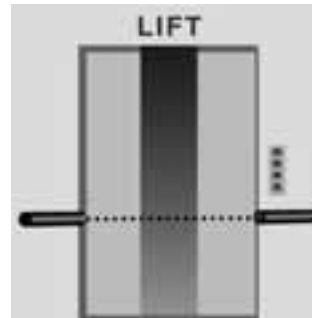
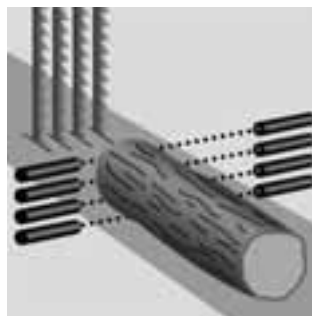

Diffuse proximity

- Detecting piece material.

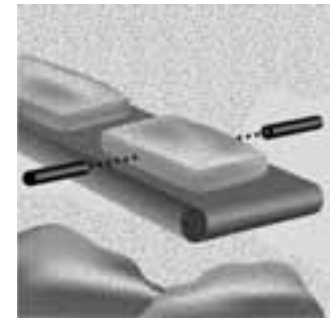
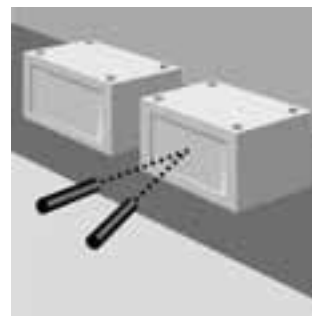

Retro reflective light barrier

- Detecting piece material.

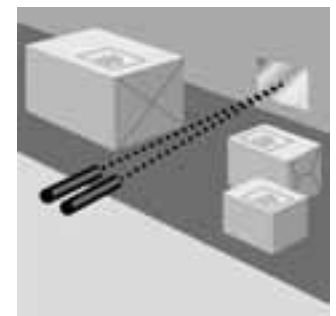

Compendium

Automatic operation

In this operation mode the transmit power will adjust automatically depending on environmental conditions. Disturbing influences will be permanently adjusted, so that the switching sensitivity is constant over the whole power range.

Operation voltage

The operation voltage consists of a nominal voltage and a tolerance. The specified nominal voltage is the voltage for which the device is designed. The tolerance is the maximum deviation from the nominal voltage. This information follows the voltage range, within which, the device will reliably work. To exceed or remain under the voltage range is not advised.

Ambient light immunity

Ambient light is the light from other light sources. The light immunity is the maximum allowed illumination level from other light sources beyond that which is normally received from the receiver, which will allow the system to work safely.

Infrared light

Infrared light is described as a radiation with a wavelength from 780 nm up to 1500 nm. Above this level is visible light.

Sensitivity indicator

The received signal power is displayed by the sensitivity indicator. This is illuminated constantly when the received signal is sufficient. If it flashes or goes off completely, then the signal is too low.

Power level

Choosing between the different available power levels allows the amplifier to adjust to different applications.

Light barrier

A light barrier is an arrangement from one or more light transmitter which one or more light receiver illuminated by a light beam. The changing of the illumination will be converted to an electrical signal.

Light curtain

By the light curtain mode the switching signal from several channels will be collected on one switching output. The additional wiring by connection of the switching outputs in serial or in parallel can be reduced.

Manual operation

The transmit power will be adjusted manually to the ambient conditions by the user.

Master- Slave

Several amplifiers can be synchronized by the master-slave connection. Disturbance from other amplifier light barriers can be prevented.

Maximum range

The maximum range is the maximum usable distance between transmitter and receiver of a through beam light barrier. The amplifier must be set on the maximum sensitivity and on the highest basic transmit level.

Modulated light

Modulated light changes intensity with a specific frequency (see transmit frequency)

Multiplex-Amplifier

Multiplex-Amplifier, referred to as "amplifier", is the combination of several light barriers controlled as one with each channel activated in sequence. By this method, interference may be prevented between each light barrier.

Multiplex speed

The multiplex speed is the required time to activate all light barriers of an amplifier, one after the other.

Reaction time

The time between interruption or clearance of the light beam and the change of the output status is called reaction time

Switching behaviour

The switching behaviour describes the behaviour of the switching output when the beam of the light barrier is interrupted or cleared. When the amplifier is set to light mode, there is a constant output as long as the beam is present. In the dark mode, the output occurs only when the beam is interrupted.

Switching delay

Switching-on or switching-off delay controls the reaction of the switching output. The switching-on delay is the time between change of the beam status and turning the switching output on. The switching-off delay is the time between change of the beam status and turning the switching output off.

Protection class

The protection class describes the protection of the device against the touching, ingress from objects or moisture according to EN6529. The protection name starts with the character IP (International Protection) and the first number as an indicator for direct contact and ingress from objects. The second number is the protection against water. The bigger the number is, the higher is the respective protection.

Transmit frequency

The transmit frequency is the number of light impulses per second.

Test input

To check the function of the system, the light of the transmitter can be switched off by this input. After activating, the switching output must change the status.

Test function

To determine malfunctions or defects at the sensor head, a control unit is included. The amplifier will indicate whether the transmitter or the receiver is defective. If nothing is defective, the test function shows the signal quality. A green LED flashes from 1 up to 10 times. The flashes are proportional to the received signal.

Teach function

The teach function enables the user to programme the switching point of the switching output. The user can decide whether the object should be recognized or should not be recognized.

Sensors



- Extremely dirt-resistant
- High penetration
- Large detection range
- Small design
- High switching accuracy
- Easy adjustment
- Cable or plug connection



Note

The sensors from Pantron can be used only with the amplifier type ISM-..., ISG-... or IMX-... .

Technical data (at +20°C)

















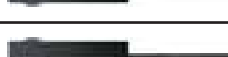



General			
Ambient temperature	-25 °C ... +65 °C		
Storage temperature	-40 °C ... +80 °C		
Vibration	10 ... 55 Hz, 1,5 mm		
Shock	30 g		
Protection class	IP 67		
Transmitter			
Type	IT-... or ITL-...	IT-...HP.. or ITH-...	ITA-...
Transmit light	Infrared 880 nm, modulated	Infrared 870 nm, modulated	Infrared 870 nm, modulated
Transmit power	40 mW / sr	70 mW / sr	350 mW / sr
Opening angle	12 °	20°	6°
Cable sheathing	PVC, Ø 3,8 mm ± 0,2 mm, black*		
Cable core construction	2x 0,25 mm ² , red / black		
Receiver			
Typ	IRL-...	IR-...	
Opening angle	25 °	25 °	
Ambient light immunity	40000 LUX	60000 LUX	
Cable sheathing	PVC, Ø 3,8 mm ± 0,2 mm, black*		
Cable core construction	1x 0,34 mm ² , yellow shielded		

* Other cable materials by request

Range overview (different sensor-amplifier combinations)

Amplifier	Sensors	Sensors						
		Transmitter Receiver	IT-... or ITL-...		IT-...HP.. or ITH-...		ITA-...	
			IRL-...	IR-...	IRL-...	IR-...	IRL-...	IR-...
ISM-Series	ISM-15xx	20 m	25 m	30 m	35 m	50 m	70 m	
	ISM-1200	7 m	15 m	10 m	25 m	20 m	55 m	
	ISM-1220	8 m	15 m	10 m	20 m	20 m	50 m	
	ISM-2000	8 m	20 m	10 m	30 m	20 m	55 m	
	ISM-4000/ISM-8000	10 m	15 m	12 m	25 m	25 m	60 m	
ISG-Series	ISG-Nxx	20 m	25 m	30 m	35 m	50 m	70 m	
	ISG-N124M	10 m	20 m	20 m	35 m	35 m	55 m	
	ISG-N1xx	10 m	20 m	20 m	35 m	35 m	55 m	
	ISG-A1xx	7 m	15 m	10 m	25 m	20 m	50 m	
IMX-Series	IMX-Nxx	10 m	20 m	15 m	30 m	25 m	50 m	
	IMX-N440/IMX-N840	10 m	20 m	15 m	30 m	20 m	40 m	
	IMX-A2034	7 m	13 m	9 m	20 m	15 m	40 m	
	IMX-A840	8 m	15 m	10 m	20 m	20 m	55 m	

Ordering table



Transmitter IT-..., ITL-...	Transmitter IT-...HP..., ITH-...	Transmitter ITA-...	Receiver	Connection	Material	Outline drawing	Picture
IT-P10-5m	IT-P10HP-5m	ITA-TLP-5	IR-P10-5m	cable 5m*	plastic	picture 1	
IT-P10-15m	IT-P10HP-15m	ITA-TLP-15	IR-P10-15m	cable 15m*			
IT-P10-3QD	IT-P10HP-3QD	ITA-TLP-B3	IR-P10-3QD	plug M8	plastic	picture 2	
IT-M12-5m	IT-M12HP-5m	ITA-CLN-5	IR-M12-5m	cable 5m*	nickel plated brass	picture 3	
IT-M12-15m	IT-M12HP-15m	ITA-CLN-15	IR-M12-15m	cable 15m*			
IT-M12VA-5m	IT-M12VAHP-5m	ITA-CLV-5	IR-M12VA-5m	cable 5m*	stainless steel	picture 3	
IT-M12VA-15m	IT-M12VAHP-15m	ITA-CLV-15	IR-M12VA-15m	cable 15m*			
IT-M12-3QD	IT-M12HP-3QD	ITA-CLN-B3	IR-M12-3QD	plug M8	nickel plated brass	picture 4	
IT-M12VA-3QD	IT-M12VAHP-3QD	ITA-CLV-B3	IR-M12VA-3QD	plug M8	stainless steel		
IT-M12-4QD	IT-M12HP-4QD	ITA-CLN-C4	IR-M12-4QD	plug M12	nickel plated brass	picture 5	
IT-M12VA-4QD	IT-M12VAHP-4QD	ITA-CLV-C4	IR-M12VA-4QD	plug M12			
IT-AS-5m				cable 5m*	plastic	picture 6	
IT-AS-15m				cable 15m*			
			IR-AS-5m	cable 5m*	plastic	picture 7	
			IR-AS-15m	cable 15m*			
IT-AS-3QD				plug M8	plastic	picture 8	
			IR-AS-3QD	plug M8	plastic	picture 9	
IT-SLA-5m	IT-SLAHP-5m	ITA-LLA-5	IR-SLA-5m	cable 5m*	aluminium	picture 10	
IT-SLA-15m	IT-SLAHP-15m	ITA-LLA-15	IR-SLA-15m	cable 15m*			
IT-SLA-3QD	IT-SLAHP-3QD	ITA-LLA-B3	IR-SLA-3QD	plug M8	aluminium	picture 11	
ITL-TSP-5	ITH-TSP-5	ITA-TSP-5	IRL-TSP-5	cable 5m*	plastic	picture 12	
ITL-TSP-15	ITH-TSP-15	ITA-TSP-15	IRL-TSP-15	cable 15m*			
ITL-TSP-B3	ITH-TSP-B3	ITA-TSP-B3	IRL-TSP-B3	plug M8	plastic	picture 13	
ITL-SSP-5	ITH-SSP-5	ITA-SSP-5	IRL-SSP-5	cable 5m*	plastic	picture 14	
ITL-SSP-15	ITH-SSP-15	ITA-SSP-15	IRL-SSP-15	cable 15m*			
ITL-SSP-5	ITH-SSP-5	ITA-SSP-5	IRL-SSP-5	plug M8	plastic	picture 15	
ITL-CSN-5	ITH-CSN-5	ITA-CSN-5	IRL-CSN-5	cable 5m*	nickel plated brass	picture 16	
ITL-CSN-15	ITH-CSN-15	ITA-CSN-15	IRL-CSN-15	cable 15m*			
ITL-CSV-5	ITH-CSV-5	ITA-CSV-5	IRL-CSV-5	cable 5m*	stainless steel	picture 16	
ITL-CSV-15	ITH-CSV-15	ITA-CSV-15	IRL-CSV-15	cable 15m*			
ITL-CSN-B3	ITH-CSN-B3	ITA-CSN-B3	IRL-CSN-B3	plug M8	nickel plated brass	picture 17	
ITL-CSV-B3	ITH-CSV-B3	ITA-CSV-B3	IRL-CSV-B3	plug M8	stainless steel		
ITL-CSN-C4	ITH-CSN-C4	ITA-CSN-C4	IRL-CSN-C4	plug M12	nickel plated brass	picture 18	
ITL-CSV-C4	ITH-CSV-C4	ITA-CSV-C4	IRL-CSV-C4	plug M12			

* Other cable lengths by request

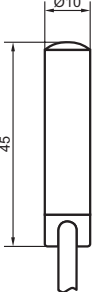
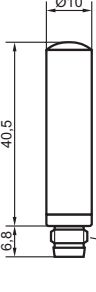
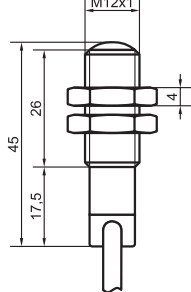
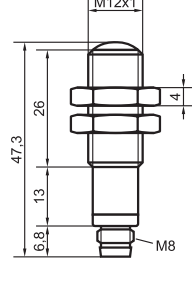
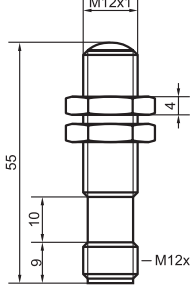
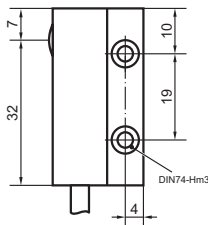
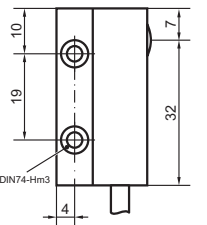
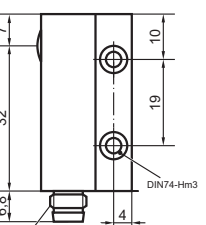
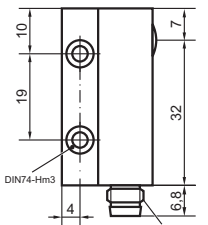
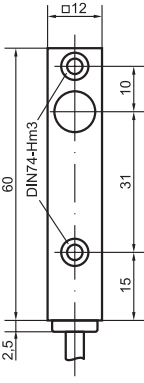
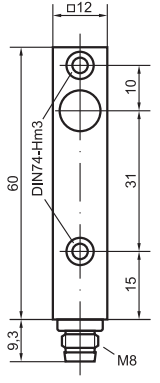
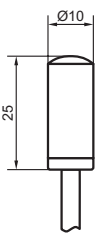
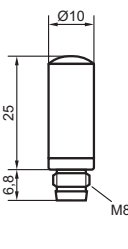
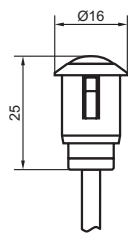
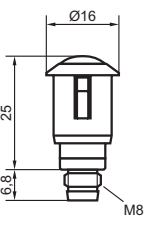
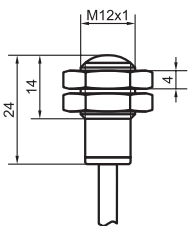
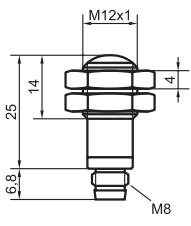
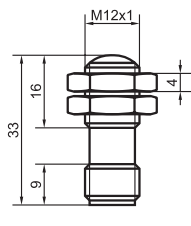
Dimension drawings (dimension in mm)

 <p>picture 1</p>	 <p>picture 2</p>	 <p>picture 3</p>	 <p>picture 4</p>	 <p>picture 5</p>
 <p>picture 6</p>	 <p>picture 7</p>	 <p>picture 8</p>	 <p>picture 9</p>	 <p>picture 10</p>
 <p>picture 11</p>	 <p>picture 12</p>	 <p>picture 13</p>	 <p>picture 14</p>	 <p>picture 15</p>
 <p>picture 16</p>	 <p>picture 17</p>	 <p>picture 18</p>		

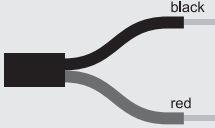
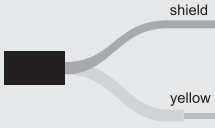
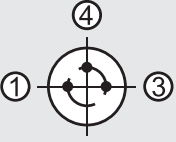
Connection diagram

Cable version				Plug version			
				 <p>plug M8</p>		 <p>plug M12</p>	
Transmitter		Receiver		Transmitter		Receiver	
Core-colour	Connection	Core-colour	Connection	PIN	Connection	PIN	Connection
red	+	yellow	+	① (brown)*	+	④ (black)*	+
black	-	shield	-	③ (blue)*	-	③ (blue)*	-

* Core-colour from the connection cable CAB-... (see page 10)



Connection cable

Plug connector M8 with open ended wires, 3-pole

Description	Order code
female straight, PVC, length 3 m	CAB-M8-S3-3
female straight, PVC, length 5 m	CAB-M8-S3-5
female straight, PUR, length 3 m	CAB-M8-S3-P3
female straight, PUR, length 5 m	CAB-M8-S3-P5
female right angle, PVC, length 3 m	CAB-M8-R3-3
female right angle, PVC, length 5 m	CAB-M8-R3-5
female right angle, PUR, length 3 m	CAB-M8-R3-P3
female right angle, PUR, length 5 m	CAB-M8-R3-P5

Plug connector M12 with open ended wires, 3-pole

Description	Order code
female straight, PVC, length 3 m	CAB-M12-S3-3
female straight, PVC, length 5 m	CAB-M12-S3-5
female straight, PUR, length 3 m	CAB-M12-S3-P3
female straight, PUR, length 5 m	CAB-M12-S3-P5
female right angle, PVC, length 3 m	CAB-M12-R3-3
female right angle, PVC, length 5 m	CAB-M12-R3-5
female right angle, PUR, length 3 m	CAB-M12-R3-P3
female right angle, PUR, length 5 m	CAB-M12-R3-P5

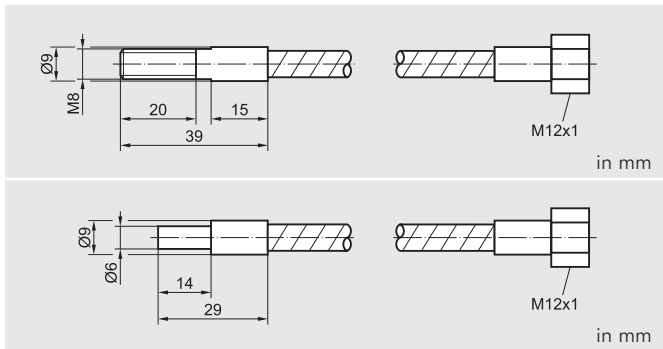

Glass fiber optic cable

Purchase order table

Description	Order code
Cable end M8, stainless coating 1 m	FOI-40V70-CB-1
Cable end M8, stainless coating 3 m	FOI-40V70-CB-3
Cable end M8, stainless coating 5 m	FOI-40V70-CB-5
Cable end Ø6, stainless coating 1 m	FOI-40V70-C9/6-1
Cable end Ø6, stainless coating 3 m	FOI-40V70-C9/6-3
Cable end Ø6, stainless coating 5 m	FOI-40V70-C9/6-5

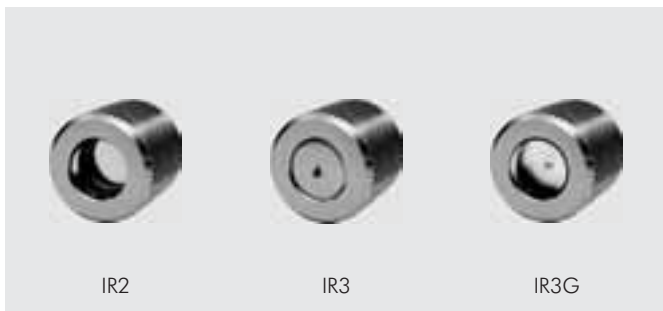

Protective glass shield / light shutter

Purchase order table

Description	Order code
Protective glass shield for sensors with M12 thread	IR2
Light shutter Ø1 mm for sensors with M12 thread	IR3
Light shutter Ø1 mm with protective glass shield for sensors with M12 thread	IR3G



Sensor mounting bracket

Purchase order table

Description	Order code
Screw clamp for sensors with Ø10mm	ISH1
Mounting clip for sensors with Ø10mm	ISH2
Strain relief with 1/2" thread for sensors with Ø10mm	ISH10



Cleaning air nozzle

Purchase order table

Description	Order code
Attachment with air connection for optic cleaning of sensors with M12 thread	ISO12



Amplifier

Product overview

		light barrier (channels)	maximum range [m]	transmit power adjustment		switching behaviour		switching delay		switching output				basic transmit level	sensor-control	transmit frequency	teach function	analog output	alarm output	test input	connection			page
				automatic	manual	light	dark			normal open	change over	semiconductor relay	pnp	npn						DIN-plug	plug	screw terminals		
ISM-Series	ISM-1510	1	70		•	•				•					1	1						•		13
	ISM-1515	1	70		•	•						•			1	1						•		13
	ISM-1520	1	70		•	•	•			•					1	1						•		14
	ISM-1525	1	70		•	•	•					•			1	1						•		14
	ISM-1530	1	70		•	•	•	•	•						1	1						•		15
	ISM-1535	1	70		•	•	•	•				•			1	1						•		15
	ISM-1200	1	55	•	•	•	•					•			4	•	2		•	•	•		•	16
	ISM-1200S	1	55	•	•	•	•					•			4	•	2		•	•	•		•	16
	ISM-1220S	1	50	•	•	•	•	•			•				4	•	2		•	•			•	17
	ISM-2000	2	55	•	•	•	•					•			4	•	1		•	•		•		18
	ISM-2000S	2	55	•	•	•	•					•			4	•	1		•	•			•	18
	ISM-4000	4	60	•	•	•	•	•				•			6	•	1		•	•	•		•	19
ISM-8000	8	60	•	•	•	•	•				•			6	•	1		•	•	•		•	20	
ISG-Series	ISG-N14	1	70		•	•					•				1	1					•			21
	ISG-N24	1	70		•	•	•				•		•	•	2	4				•	•			22
	ISG-N34	1	70		•	•	•	•			•		•	•	2	4				•	•			23
	ISG-N37	1	70		•	•	•	•			•		•	•	2	4			•		•			24
	ISG-N124M	1	55		•	•	•				•		•	•	2	•	2		•		•	•		25
	ISG-N127	1	55		•	•	•						•	•	2	•	4		•		•			26
	ISG-N128	1	55		•	•	•				•			•	2	•	4		•		•			27
	ISG-N137	1	55		•	•	•	•					•	•	2	•	4		•		•			28
	ISG-N138	1	55		•	•	•	•						•	2	•	4		•		•			29
	ISG-A113	1	50	•		•							•	•	2	1			•		•			30
	ISG-A114	1	50	•		•					•				2	1			•		•			31
	ISG-A124	1	50	•		•	•				•				4	2			•	•	•			32
	ISG-A134	1	50	•		•	•	•			•				4	2			•	•	•			33
	ISG-A143	1	50	•		•	•						•	•	2	2	•		•	•	•			34
	ISG-A144	1	50	•		•	•				•				2	2	•		•	•	•			35
IMX-Series	IMX-N23	2	50		•	•	•						•	•	2	1					•			36
	IMX-N24	2	50		•	•	•		•						2	1					•			37
	IMX-N33	2	50		•	•	•	•					•	•	2	1					•			38
	IMX-N34	2	50		•	•	•	•	•						2	1					•			39
	IMX-N440	4	40		•	•	•	•		•					2	1							•	40
	IMX-N840	8	40		•	•	•	•	•						2	1							•	41
	IMX-A2034	2	40	•		•	•	•	•						4	1					•			42
	IMX-A840	8	55	•		•	•	•	•						2	1			•				•	43

1-channel Amplifier ISM-1510

- Detection range up to 70 m
- Sensitivity adjustable with potentiometer
- Operating voltage 24 V AC or DC
- Floating distance switching output (ISM-1510... with relay and ISM-1515... with semiconductor relay)
- Connections are pluggable
- Mounting for DIN rail

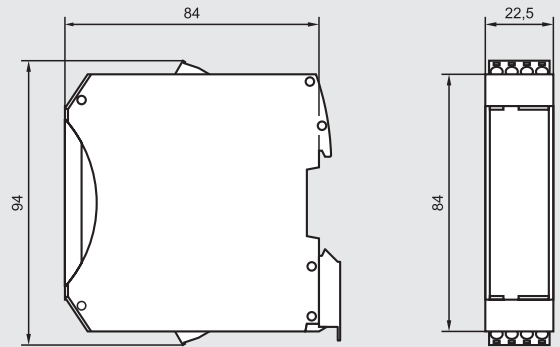

in mm

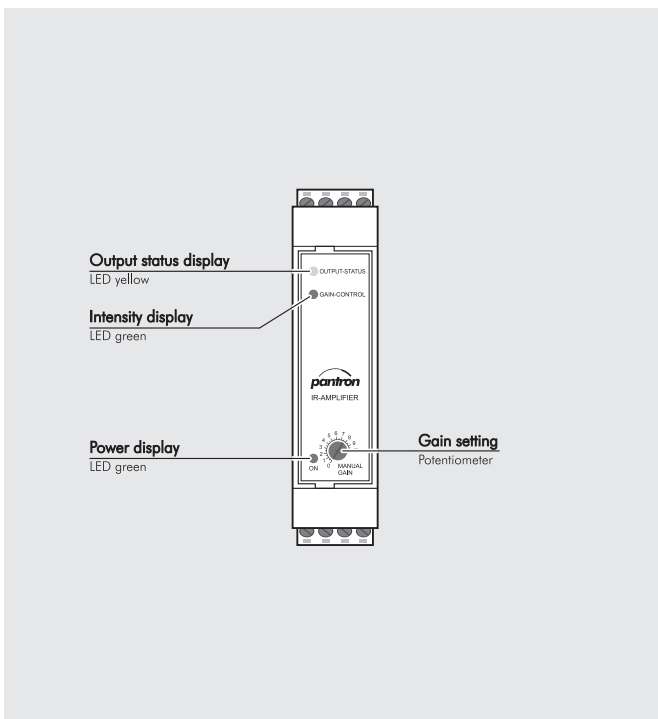

Technical data (at +20°C)

Operating voltage	24 V AC / ± 10 % / 2,4 VA 24 V DC / ± 10 % / 2,4 W
Operating basis	modulated infrared light
Transmit frequency	4,0 kHz
Transmit power	manual
Switching behaviour	light
Basic transmit level	high
Switching delay	-
Switching output ISM-1510	Relay, change over
max. operation values	5 A / 230 V AC (24 V DC)
reaction time	36 ms
Switching output ISM-1515	Semiconductor relay, NO
max. operation values	100 mA / 60 V AC (DC)
reaction time	36 ms
Housing material	Polyamide, light grey
Protection class	IP 20
Connection	plug with screw terminals
Operation temperature	-25 °C ... +50 °C

Purchase order table

Switching output	Order table
Relay	ISM-1510/24V
Semiconductor relay	ISM-1515/24V

Accessories

Power supply 24 V DC	PSU-1000/95...265VAC
Protective enclosure	PanBox 1x1

Maximum Range

	Receiver IRL-...	Receiver IR-...
Transmitter IT-..., ITL-...	20 m	25 m
Transmitter IT-...HR..., ITH-...	30 m	35 m
Transmitter ITA-...	50 m	70 m

Connection diagram

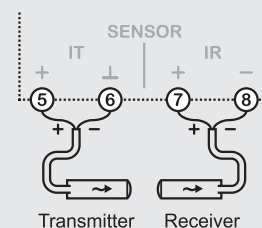
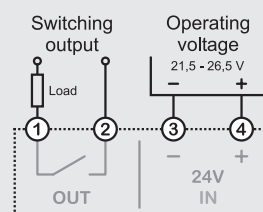

ISM-Series

1-channel Amplifier **ISM-1520**

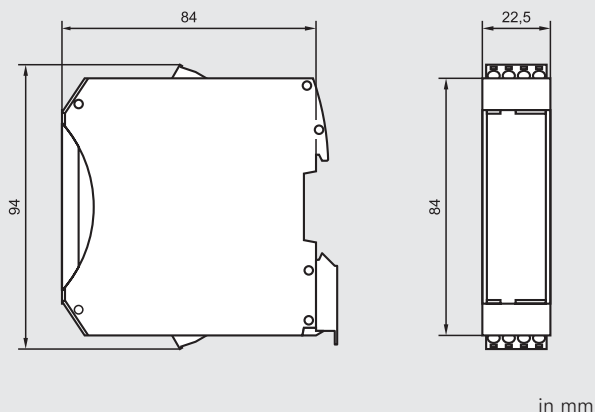

- Detection range up to 70 m
- Sensitivity adjustable with potentiometer
- Operating voltage 24 V AC or DC
- Basic transmit level 2-fold selectable
- Switching behaviour light / dark selectable
- Floating distance switching output (ISM-1520... with relay and ISM-1525... with semiconductor relay)
- Connections are pluggable
- Mounting for DIN rail

Technical data (at +20°C)

Operating voltage	24 V AC / ±10 % / 2,4 VA 24 V DC / ±10 % / 2,4 W
Operating basis	modulated infrared light
Transmit frequency	4,0 kHz
Transmit power	manual
Switching behaviour	light / dark
Basic transmit level	low / high
Switching delay	-
Switching output ISM-1520	Relay, change over
max. operation values	5 A / 230 V AC (24 V DC)
reaction time	36 ms
Switching output ISM-1525	Semiconductor relay, NO
max. operation values	100 mA / 60 V AC (DC)
reaction time	36 ms
Housing material	Polyamide, light grey
Protection class	IP 20
Connection	plug with screw terminals
Operation temperature	-25 °C ... +50 °C

Purchase order table

Switching output	Order table
Relay	ISM-1520/24V
Semiconductor relay	ISM-1525/24V

Accessories

Power supply 24 V DC	PSU-1000/95...265VAC
Protective enclosure	PanBox 1x1

Maximum Range

	Receiver IRL-...	Receiver IR-...
Transmitter IT-..., ITL-...	20 m	25 m
Transmitter IT-...HP-..., ITH-...	30 m	35 m
Transmitter ITA-...	50 m	70 m

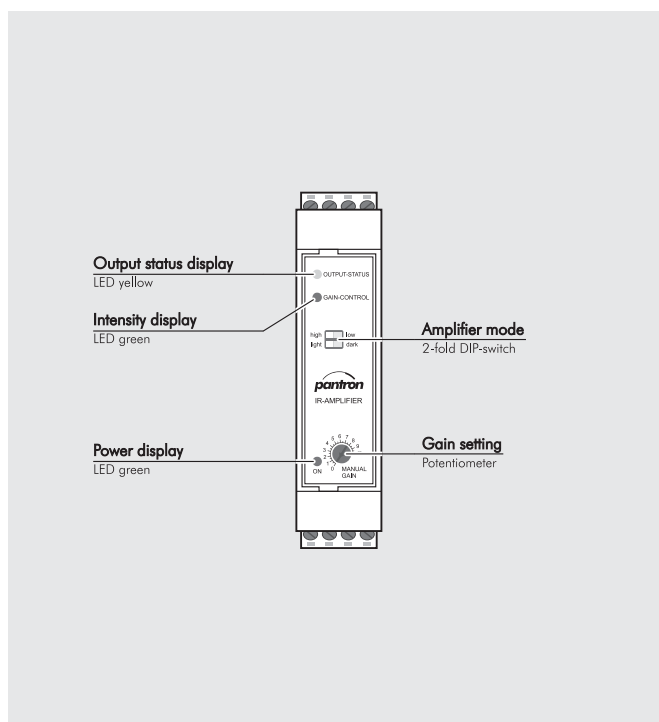

Amplifier mode (Factory setting is marked in white)

	1	Basic transmit level	high	low
			<input type="checkbox"/>	<input type="checkbox"/>
	2	Switching behaviour	light	dark
			<input type="checkbox"/>	<input type="checkbox"/>

Connection diagram

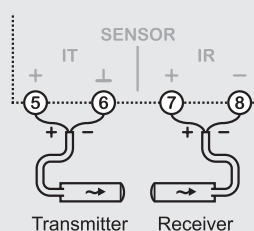
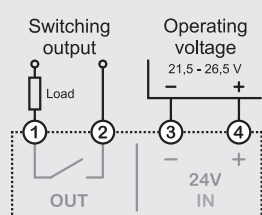

1-channel Amplifier ISM-1530

- Detection range up to 70 m
- Sensitivity adjustable with potentiometer
- Operating voltage 24 V AC or DC
- Basic transmit level 2-fold switchable
- Switching behaviour light / dark selectable
- Switching-on and switching-off delay
- Floating distance switching output (ISM-1530... with relay and ISM-1535... with semiconductor relay)
- Connections are pluggable
- Mounting for DIN rail

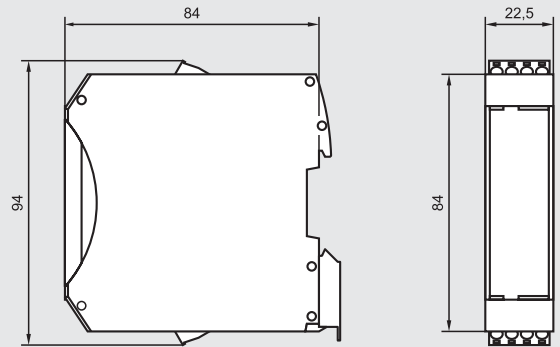

in mm

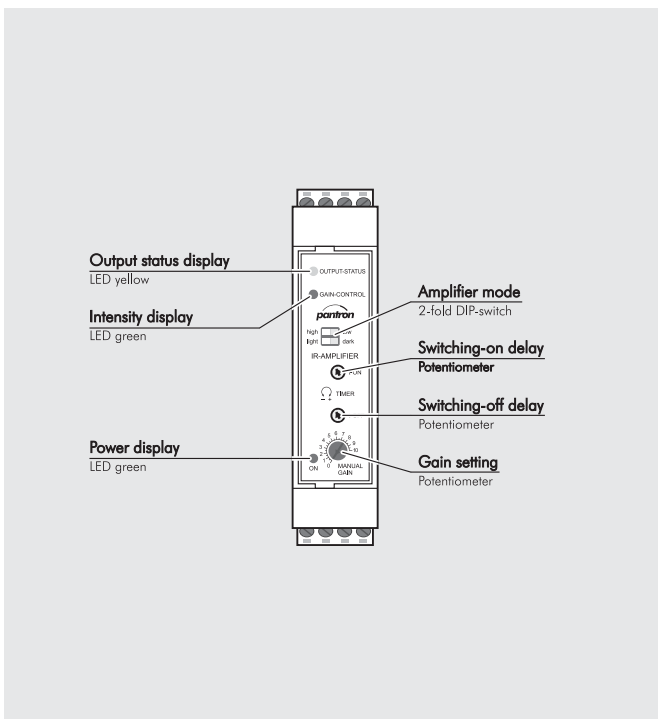

Technical data (at +20°C)

Operating voltage	24 V AC / ± 10 % / 2,4 VA 24 V DC / ± 10 % / 2,4 W
Operating basis	modulated infrared light
Transmit frequency	4,0 kHz
Transmit power	manual
Switching behaviour	light / dark
Basic transmit level	low / high
Switching delay	0 ... 15 s
Switching output ISM-1530	Relay, change over
max. operation values	5 A / 230 V AC (24 V DC)
reaction time	36 ms
Switching output ISM-1535	Semiconductor relay, NO
max. operation values	100 mA / 60 V AC (DC)
reaction time	36 ms
Housing material	Polyamide, light grey
Protection class	IP 20
Connection	plug with screw terminals
Operation temperature	-25 °C ... +50 °C

Purchase order table

Switching output	Order table
Relay	ISM-1530/24V
Semiconductor relay	ISM-1535/24V

Accessories

Power supply 24 V DC	PSU-1000/95...265VAC
Protective enclosure	PanBox 1x1

Maximum Range

	Receiver IRL...	Receiver IR...
Transmitter IT..., ITL...	20 m	25 m
Transmitter IT...HR..., ITH...	30 m	35 m
Transmitter ITA...	50 m	70 m

Amplifier mode (Factory setting is marked in white)

1	Basic transmit level	high	low
2	Switching behaviour	light	dark

Connection diagram

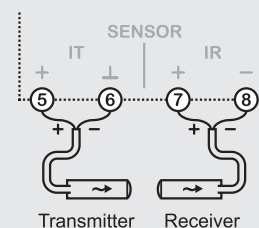
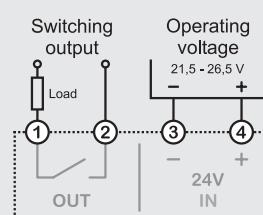

1-channel Amplifier ISM-1200

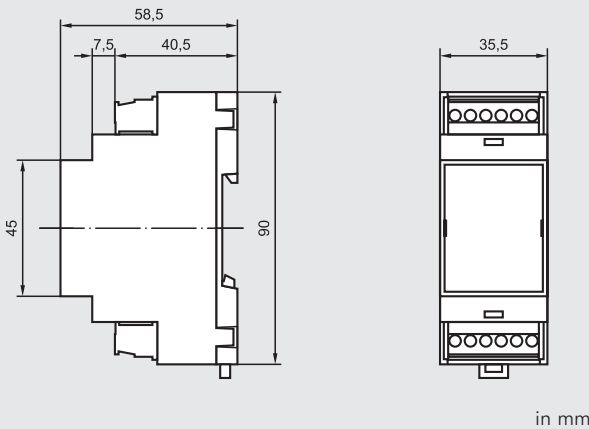

- Detection range up to 55 m
- Manual / automatic operation selectable
- Basic transmit level 2-fold selectable
- Switching behaviour light / dark selectable
- Transmit frequency 2-fold selectable
- Floating distance switching output - short circuit proof
- Analog output
- Alarm output for power limit
- Test input for system check
- Sensor control
- Mounting for DIN rail

Technical data (at +20°C)

Operating voltage	24 V DC / $\pm 20\%$ / 2,4 W
Operating basis	modulated infrared light
Transmit frequency	3,7 kHz / 4,3 kHz
Transmit power	manual / automatic
Switching behaviour	light / dark
Basic transmit level	low / high
Switching delay	-
Switching output	Semiconductor relay, NO
max. operation values	100 mA / 60 V DC (AC)
reaction time	24 ms
Alarm, Error output	pnp, 100 mA / 24 V DC
Analog output	0 ... 10 V DC
Test input	0 ... 30 V DC
Housing material	NORYL, light grey
Protection class	IP 20
Connection	see purchase order table
Operation temperature	-25 °C ... +50 °C

Purchase order table

Connection	Order table
Plug with screw terminals	ISM-1200/24VDC
Screw terminals	ISM-1200S/24VDC

Accessories

Power supply 24 V DC	PSU-1000/95...265VAC
Protective enclosure	PanBox 1x1

Maximum Range

	Receiver IRL-...	Receiver IR-...
Transmitter IT-..., ITL-...	7 m	15 m
Transmitter IT-...HP..., ITH-...	10 m	25 m
Transmitter ITA-...	20 m	55 m

Connection diagram

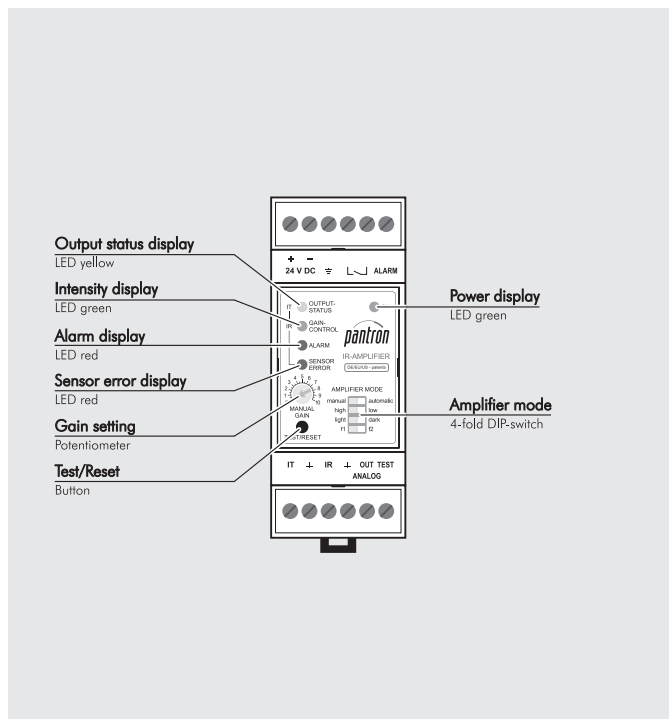
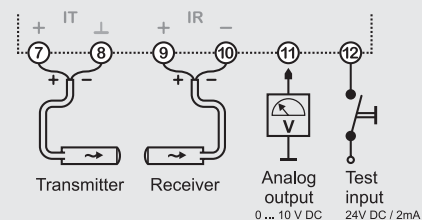
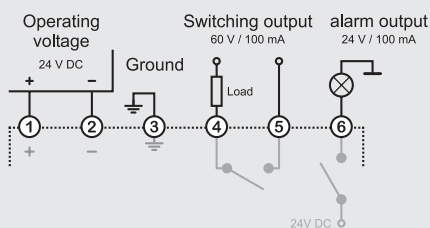

Amplifier mode (Factory setting is marked in white)

		manual	automatic
1	Operation mode	<input checked="" type="checkbox"/>	<input type="checkbox"/>
2	Basic transmit level	<input type="checkbox"/>	<input checked="" type="checkbox"/>
3	Switching behaviour	<input checked="" type="checkbox"/>	<input type="checkbox"/>
4	Transmit frequency	<input type="checkbox"/>	<input checked="" type="checkbox"/>

1-channel Amplifier ISM-1220

- Detection range up to 50 m
- Manual / automatic operation selectable
- Basic transmit level 2-fold selectable
- Switching behaviour light / dark selectable
- Transmit frequency 2-fold selectable
- Relay output, change over
- Alarm output for power limit
- Test input for system check
- Sensor control
- Mounting for DIN rail

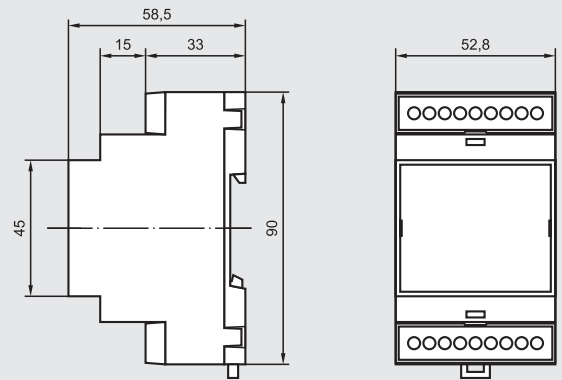

in mm

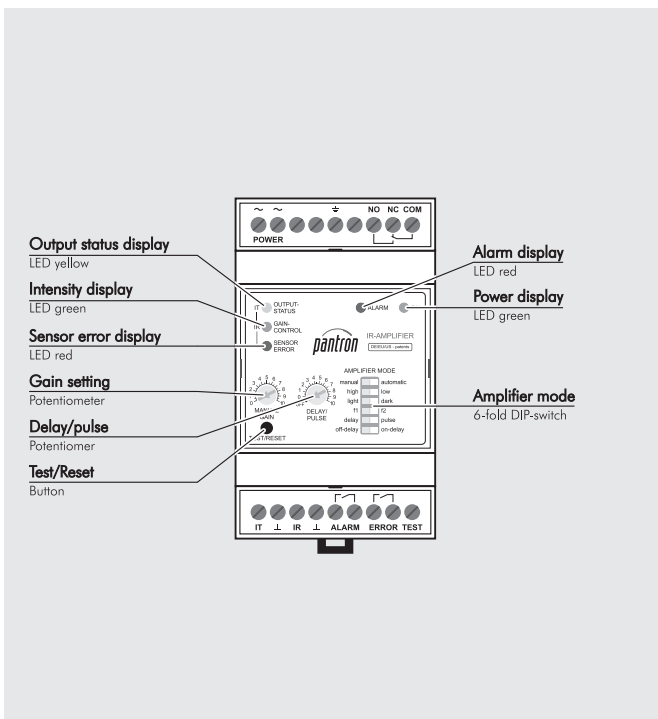

Technical data (at +20°C)

Operating voltage	see purchase order table
Operating basis	modulated infrared light
Transmit frequency	3,7 kHz / 4,3 kHz
Transmit power	manual / automatic
Switching behaviour	light / dark
Basic transmit level	low / high
Switching delay	0 ... 10 s
Switching output	Relay, change over
max. operation values	5 A / 230 V AC (24 V DC)
reaction time	36 ms
Alarm, Error output	Semiconductor relay, NO
max. operation values	100 mA / 24 V AC (DC)
Analog output	-
Test input	0 ... 30 V DC
Housing material	NORYL, light grey
Protection class	IP 20
Connection	screw terminals
Operation temperature	-25 °C ... +50 °C

Purchase order table

Operating voltage	Order table
230 V AC / ±10 % / 4,8 VA	ISM-1220S/230VAC
115 V AC / ±10 % / 4,8 VA	ISM-1220S/230VAC
24 V AC / ±10 % / 4,8 VA	ISM-1220S/230VAC

Accessories

Power supply 24 V DC	PSU-1000/95...265VAC
Protective enclosure	PanBox 1x1

Maximum Range

	Receiver IRL-...	Receiver IR-...
Transmitter IT-..., ITL-...	8 m	15 m
Transmitter IT-...HR..., ITH-...	10 m	20 m
Transmitter ITA-...	20 m	50 m

Amplifier mode (Factory setting is marked in white)

	1	2	3	4	5	6
Operation mode	manual	automatic				
Basic transmit level	high	low				
Switching behaviour	light	dark				
Transmit frequency	3,7 kHz	4,3 kHz				
Switching method	delay	pulse				
Switching reaction	on	off				

Connection diagram

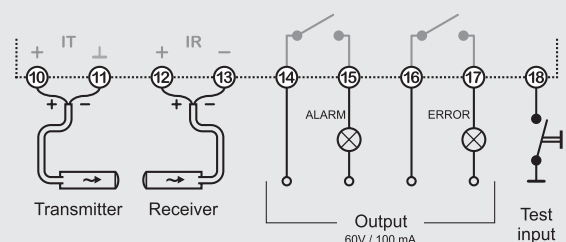
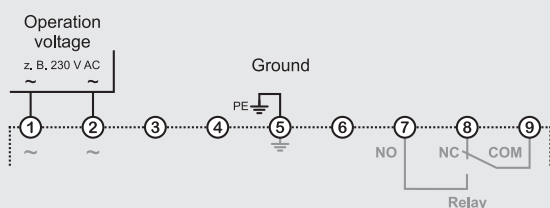

ISM-Series

2-channel multiplex Amplifier ISM-2000

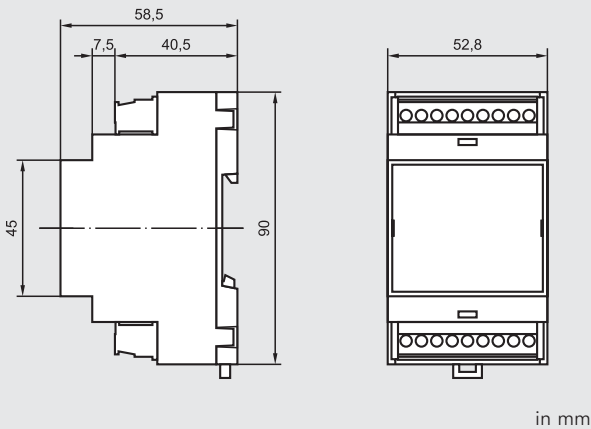

in mm

- Detection range up to 55 m
- Manual / automatic operation selectable
- Basic transmit level 2-fold selectable
- Switching behaviour light / dark selectable
- Floating distance switching outputs - short circuit proof
- Alarm output for power limit
- Test input for system check
- Sensor control
- Mounting for DIN rail

Technical data (at +20°C)

Operating voltage	24 V DC / ±20 % / 3,6 W
Operating basis	modulated infrared light
Transmit frequency	3,9 kHz
Transmit power	manual / automatic
Switching behaviour	light / dark
Basic transmit level	low / high
Multiplex speed	8 ms
Switching delay	-
Switching output	Semiconductor relay, 2x NO
max. operation values	100 mA / 60 V DC (AC)
reaction time	24 ms
Alarm, Error output	pnp, 100 mA / 24 V DC
Analog output	-
Test input	0 ... 30 V DC
COM-interface	-
Housing material	NORYL, light grey
Protection class	IP 20
Connection	see purchase order table
Operation temperature	-25 °C ... +50 °C

Purchase order table

Connection	Order table
Plug with screw terminals	ISM-2000/24VDC
Screw terminals	ISM-2000S/24VDC

Accessories

Power supply 24 V DC	PSU-1000/95...265VAC
Protective enclosure	PanBox 1x2

Maximum Range

	Receiver IRL-...	Receiver IR-...
Transmitter IT-..., ITL-...	8 m	20 m
Transmitter IT-...HP..., ITH-...	10 m	30 m
Transmitter ITA-...	20 m	55 m

Connection diagram

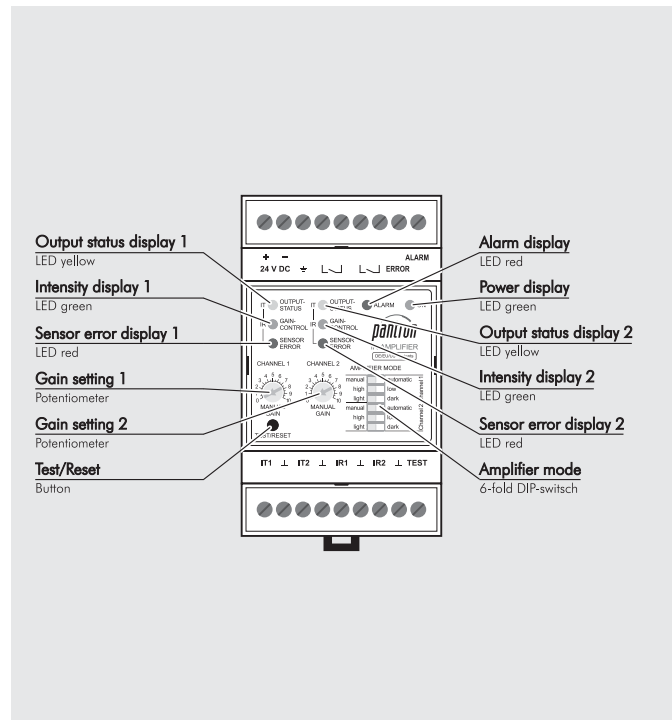
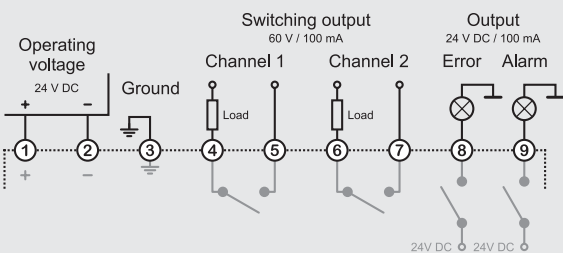

Amplifier mode (Factory setting is marked in white)

	1	Operating basis channel 1	manual	automatic
	2	Basic transmit power channel 1	high	low
	3	Switching behaviour channel 1	light	dark
	4	Operating basis channel 2	manual	automatic
	5	Basic transmit power channel 2	high	low
	6	Switching behaviour channel 2	light	dark

4-channel multiplex Amplifier ISM-4000

- Detection range up to 60 m
- Menu-driven operation with display or PC-software
- Manual / automatic operation selectable
- Switching behaviour light / dark selectable
- Switching delay
- Floating distance switching outputs - short circuit proof
- Alarm output for power limit
- Analog output
- Test input for system check
- Sensor control
- Mounting for DIN rail

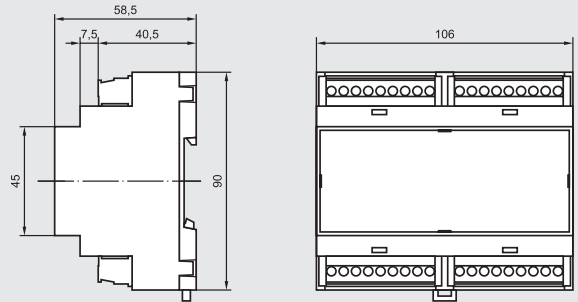

in mm

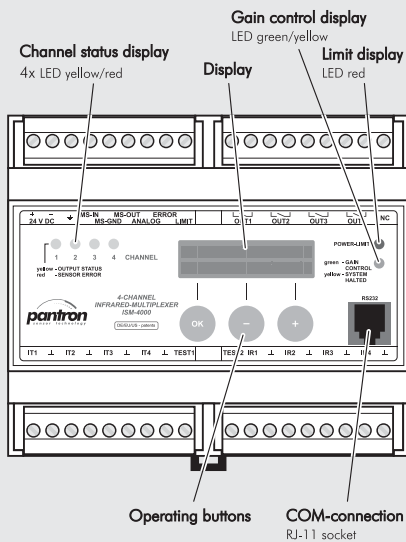

Technical data (at +20°C)

Operating voltage	24 V DC / $\pm 20\%$ / 6,5 W
Operating basis	modulated infrared light
Transmit frequency	4,0 kHz
Transmit power	manual / automatic
Switching behaviour	light / dark
Basic transmit level	man1 / man2 / (auto1 to auto4)
Multiplex speed	18 ms
Switching delay	0 ... 60 s
Switching output	Semiconductor relay, 4x NO
max. operation values	100 mA / 60 V DC (AC)
reaction time	20 ms
Alarm, Error output	pnp, 100 mA / 24 V DC
Analog output	0 ... 10 V DC
Test input	0 ... 30 V DC
COM-interface	RS232
Housing material	NORYL, light grey
Protection class	IP 20
Connection	see purchase order table
Operation temperature	0 °C ... +50 °C

Purchase order table

Connection	Order table
Plug with screw terminals	ISM-4000/24VDC

Accessories

Communication cable	CAB-COM-2m
Protective enclosure	PanBox 1x4

Maximum Range

	Receiver IRL-...	Receiver IR-...
Transmitter IT-..., ITL-...	10 m	15 m
Transmitter IT-...HR..., ITH-...	12 m	25 m
Transmitter ITA-...	25 m	60 m

Connection diagram

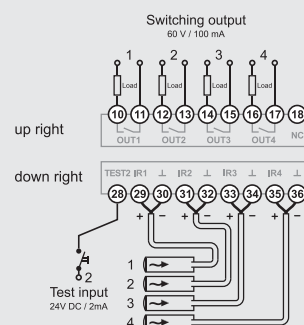
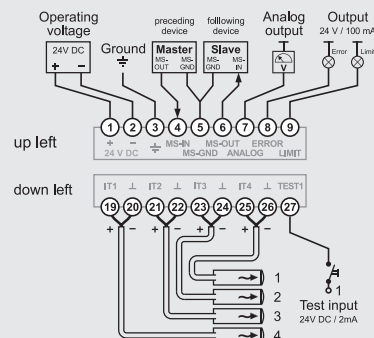

ISM-Series

8-channel multiplex Amplifier ISM-8000

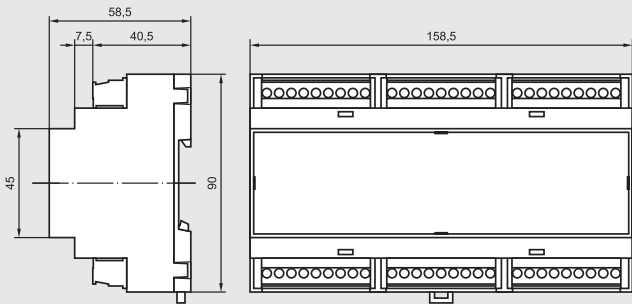

in mm

- Detection range up to 60 m
- Menu-driven operation with display or PC-software
- Manual / automatic operation selectable
- Switching behaviour light / dark selectable
- Switching delay
- Floating distance switching outputs - short circuit proof
- Alarm output for power limit
- Analog output
- Test input for system check
- Sensor control
- Mounting for DIN rail

Technical data (at +20°C)

Operating voltage	24 V DC / $\pm 20\%$ / 8,5 W
Operating basis	modulated infrared light
Transmit frequency	4,0 kHz
Transmit power	manual / automatic
Switching behaviour	light / dark
Basic transmit level	man1 / man2 / (auto1 to auto4)
Multiplex speed	34 ms
Switching delay	0 ... 60 s
Switching output	Semiconductor relay, 8x NO
max. operation values	100 mA / 60 V DC (AC)
reaction time	36 ms
Alarm, Error output	pnp, 100 mA / 24 V DC
Analog output	0 ... 10 V DC
Test input	0 ... 30 V DC
COM-interface	RS232
Housing material	NORYL, light grey
Protection class	IP 20
Connection	see purchase order table
Operation temperature	0 °C ... +50 °C

Purchase order table

Connection	Order table
Plug with screw terminals	ISM-8000/24VDC

Accessories

Communication cable	CAB-COM-2m
Protective enclosure	PanBox 1x8

Maximum Range

	Receiver IRL-...	Receiver IR-...
Transmitter IT-..., ITL-...	10 m	15 m
Transmitter IT-...HP-..., ITH-...	12 m	25 m
Transmitter ITA-...	25 m	60 m

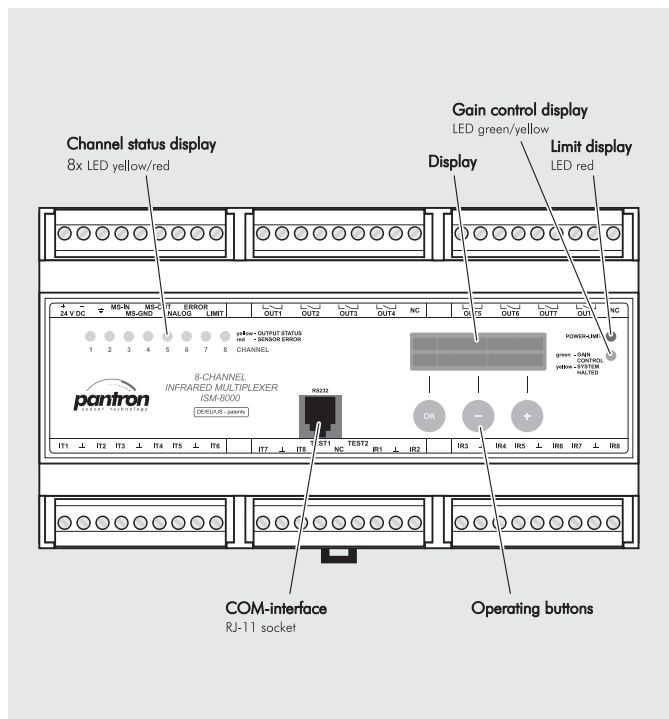

Connection diagram

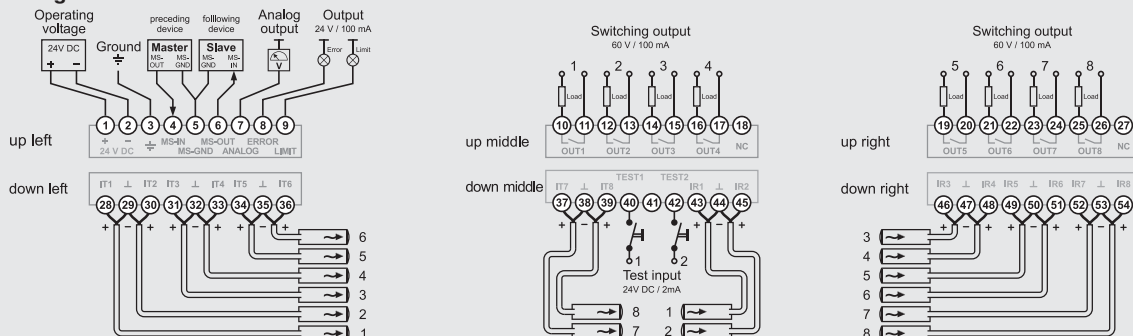

1-channel Amplifier **ISG-N14**

- Detection range up to 70 m
- Sensitivity adjustable with potentiometer
- Relay output, change over

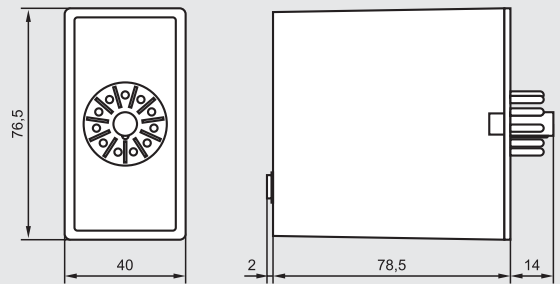

in mm

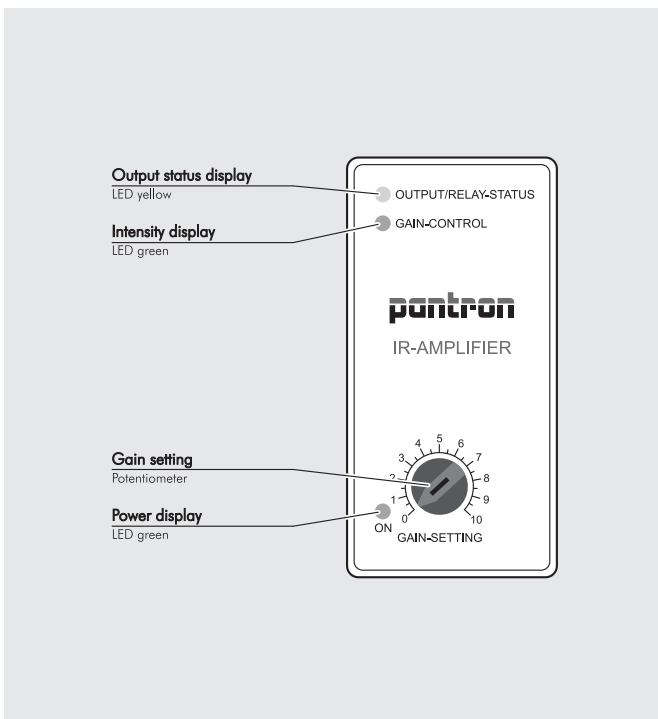

Technical data (at +20°C)

Operating voltage	see purchase order table
Operating basis	modulated infrared light
Transmit frequency	4,0 kHz
Transmit power	manual
Switching behaviour	light
Basic transmit level	high
Switching delay	-
Switching output relay	change over, 5 A / 230 V AC (24 V DC)
reaction time	36 ms
Switching output transistor...AC	-
...DC	-
reaction time	-
Alarm output	-
Test input	-
Housing material	plastic
Protection class	IP 40
Connection	11-pin DIN-plug
Operation temperature	-25 °C ... +50 °C

Purchase order table

Operating voltage	Order table
230 V AC / ±10 % / 3,8 VA	ISG-N14/230VAC
115 V AC / ±10 % / 3,8 VA	ISG-N14/115VAC
24 V AC / ±10 % / 3,8 VA	ISG-N14/24VAC
24 V DC / ±20 % / 1,9 W	ISG-N14/24VDC

Accessories

11-pole DIN-socket	ISO1
Protective enclosure	PanBox 1x1

Maximum Range

	Receiver IRL-...	Receiver IR-...
Transmitter IT-..., ITL-...	20 m	25 m
Transmitter IT-...HP..., ITH-...	30 m	35 m
Transmitter ITA-...	50 m	70 m

Connection diagram

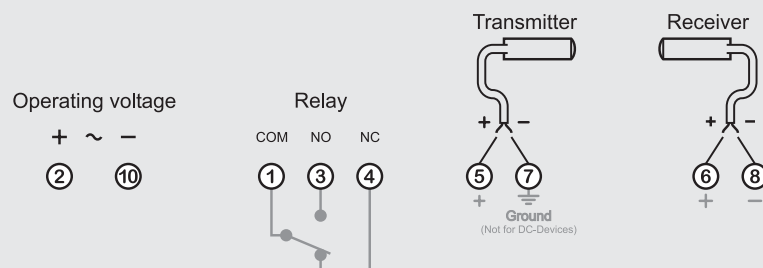

ISG-Series

1-channel Amplifier ISG-N24

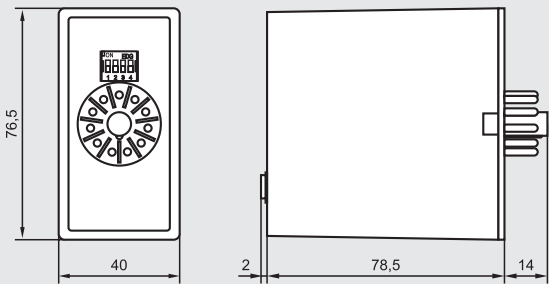

in mm

- Detection range up to 70 m
- Sensitivity adjustable with potentiometer
- Basic transmit level 2-fold selectable
- Switching behaviour light / dark selectable
- Transmit frequency 4-fold selectable
- Relay output, change over
- Transistor output, pnp / npn
- Test input for system check

Technical data (at +20°C)

Operating voltage	see purchase order table
Operating basis	modulated infrared light
Transmit frequency [kHz]	3,5 / 3,8 / 4,0 / 4,4
Transmit power	manual
Switching behaviour	light / dark
Basic transmit level	low / high
Switching delay	-
Switching output relay	change over, 5 A / 230 V AC (24 V DC)
reaction time	36 ms
Switching output transistor...AC	npn, 100 mA/30 V DC; pnp, 5mA/12 V DC
...DC	npn / pnp, 100 mA / 30 V DC
reaction time	36 ms
Alarm output	-
Test input	24 V DC
Housing material	plastic
Protection class	IP 40
Connection	11-pin DIN-plug
Operation temperature	-25 °C ... +50 °C

Purchase order table

Operating voltage	Order table
230 V AC / ±10 % / 4,2 VA	ISG-N24/230VAC
115 V AC / ±10 % / 4,2 VA	ISG-N24/115VAC
24 V AC / ±10 % / 4,2 VA	ISG-N24/24VAC
24 V DC / ±20 % / 2,0 W	ISG-N24/24VDC

Accessories

11-pole DIN-socket	ISO1
Protective enclosure	PanBox 1x1

Maximum Range

	Receiver IRL-...	Receiver IR-...
Transmitter IT-..., ITL-...	20 m	25 m
Transmitter IT-...HP..., ITH-...	30 m	35 m
Transmitter ITA-...	50 m	70 m

Connection diagram

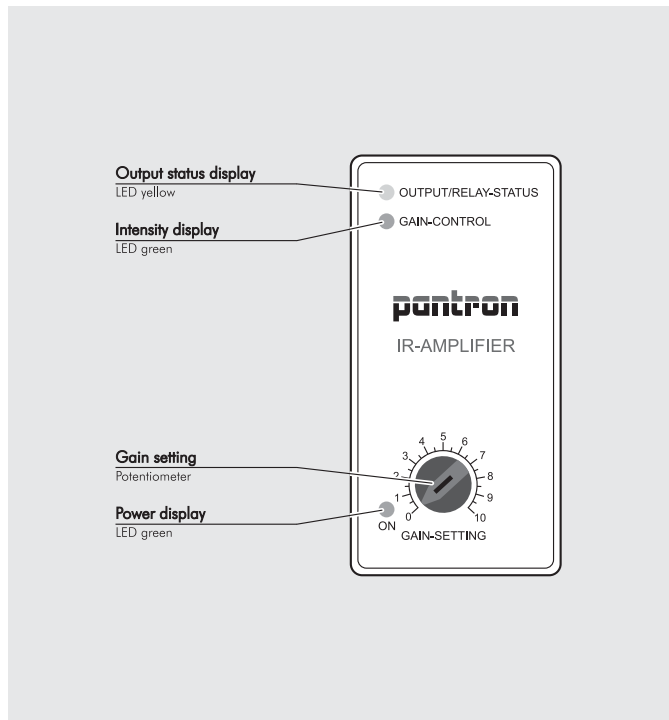
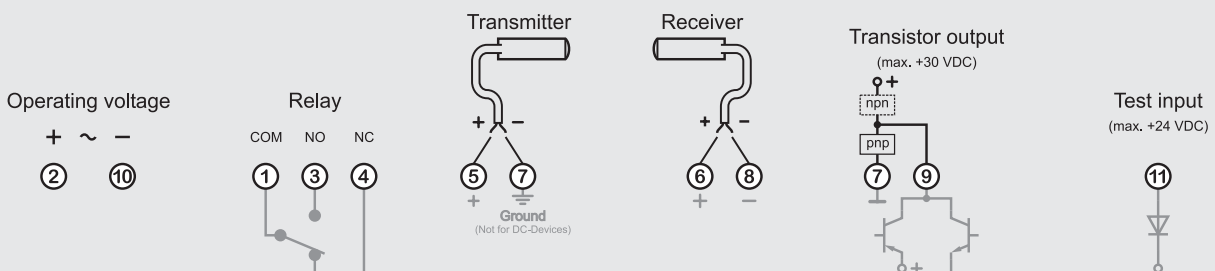

Amplifier mode (Factory setting is marked in white)



	1	2		3	4	
Basic transmit level	low	high	Switching behaviour	dark	light	Transmit frequency
	ON	OFF	ON	OFF	OFF	3,5 kHz
						3,8 kHz
						4,0 kHz
						4,4 kHz

1-channel Amplifier ISG-N34

- Detection range up to 70 m
- Sensitivity adjustable with potentiometer
- Basic transmit level 2-fold selectable
- Switching behaviour light / dark selectable
- Transmit frequency 4-fold selectable
- Switching delay
- Relay output, change over
- Transistor output, pnp / npn
- Test input for system check

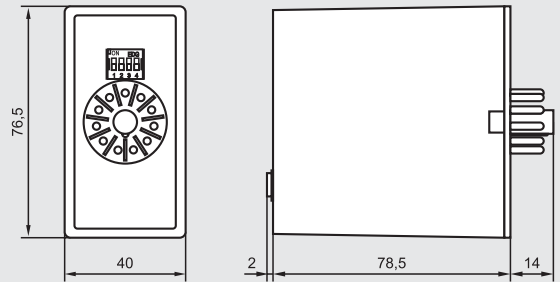

in mm

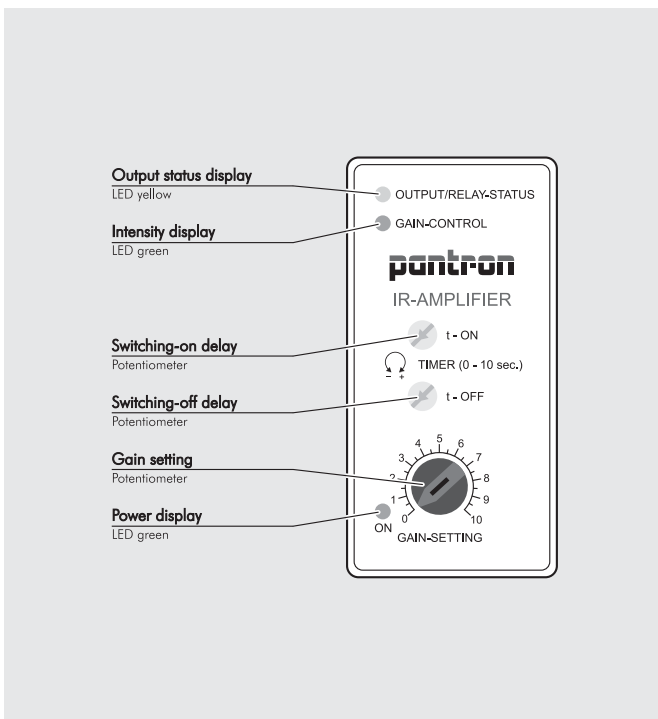

Technical data (at +20°C)

Operating voltage	see purchase order table
Operating basis	modulated infrared light
Transmit frequency [kHz]	3,5 / 3,8 / 4,0 / 4,4
Transmit power	manual
Switching behaviour	light / dark
Basic transmit level	low / high
Switching delay	0 ... 10 s
Switching output relay	change over, 5 A / 230 V AC (24 V DC)
reaction time	36 ms
Switching output transistor...AC	nnp, 100 mA/30 V DC; pnp, 5mA/12 V DC
...DC	nnp / pnp, 100 mA / 30 V DC
reaction time	36 ms
Alarm output	-
Test input	24 V DC
Housing material	plastic
Protection class	IP 40
Connection	11-pin DIN-plug
Operation temperature	-25 °C ... +50 °C

Purchase order table

Operating voltage	Order table
230 V AC / ±10 % / 4,2 VA	ISG-N34/230VAC
115 V AC / ±10 % / 4,2 VA	ISG-N34/115VAC
24 V AC / ±10 % / 4,2 VA	ISG-N34/24VAC
24 V DC / ±20 % / 2,0 W	ISG-N34/24VDC

Accessories

11-pole DIN-socket	ISO1
Protective enclosure	PanBox 1x1

Maximum Range

	Receiver IRL-...	Receiver IR-...
Transmitter IT-..., ITL-...	20 m	25 m
Transmitter IT-...HR..., ITH-...	30 m	35 m
Transmitter ITA-...	50 m	70 m

Amplifier mode (Factory setting is marked in white)



1		2		3	4
Basic transmit level		Switching behaviour		Transmit frequency	
low	ON	dark	ON	3,5 kHz	ON ON
high	OFF	light	OFF	3,8 kHz	ON OFF
				4,0 kHz	OFF ON
				4,4 kHz	OFF OFF

Connection diagram

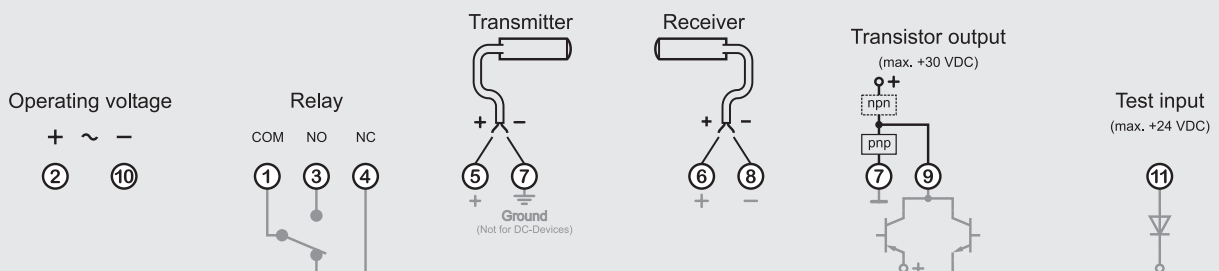

ISG-Series

1-channel Amplifier ISG-N37

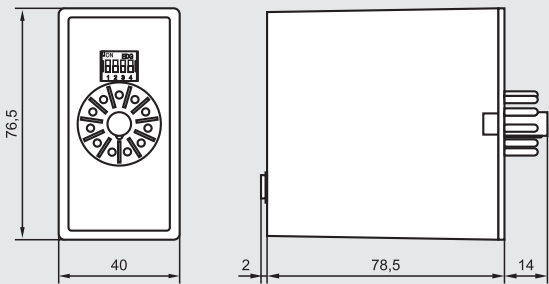

in mm

- Detection range up to 70 m
- Sensitivity adjustable with potentiometer
- Basic transmit level 2-fold selectable
- Switching behaviour light / dark selectable
- Transmit frequency 4-fold selectable
- Switching delay
- Relay output, change over
- Transistor output, pnp / npn
- Alarm output for power limit

Technical data (at +20°C)

Operating voltage	see purchase order table
Operating basis	modulated infrared light
Transmit frequency [kHz]	3,5 / 3,8 / 4,0 / 4,4
Transmit power	manual
Switching behaviour	light / dark
Basic transmit level	low / high
Switching delay	0 ... 10 s
Switching output relay	change over, 5 A / 230 V AC (24 V DC)
reaction time	36 ms
Switching output transistor...AC	npn, 100 mA/30 V DC; pnp, 5mA/12 V DC
...DC	npn / pnp, 100 mA / 30 V DC
reaction time	36 ms
Alarm output ...AC	npn, 100 mA/30 V DC; pnp, 5mA/12 V DC
...DC	npn / pnp, 100 mA / 30 V DC
Test input	24 V DC
Housing material	plastic
Protection class	IP 40
Connection	11-pin DIN-plug
Operation temperature	-25 °C ... +50 °C

Purchase order table

Operating voltage	Order table
230 V AC / ±10 % / 4,1 VA	ISG-N37/230VAC
115 V AC / ±10 % / 4,1 VA	ISG-N37/115VAC
24 V AC / ±10 % / 4,1 VA	ISG-N37/24VAC
24 V DC / ±20 % / 2,0 W	ISG-N37/24VDC

Accessories

11-pole DIN-socket	ISO1
Protective enclosure	PanBox 1x1

Maximum Range

	Receiver IRL-...	Receiver IR-...
Transmitter IT-..., ITL-...	20 m	25 m
Transmitter IT-...HP-..., ITH-...	30 m	35 m
Transmitter ITA-...	50 m	70 m

Connection diagram

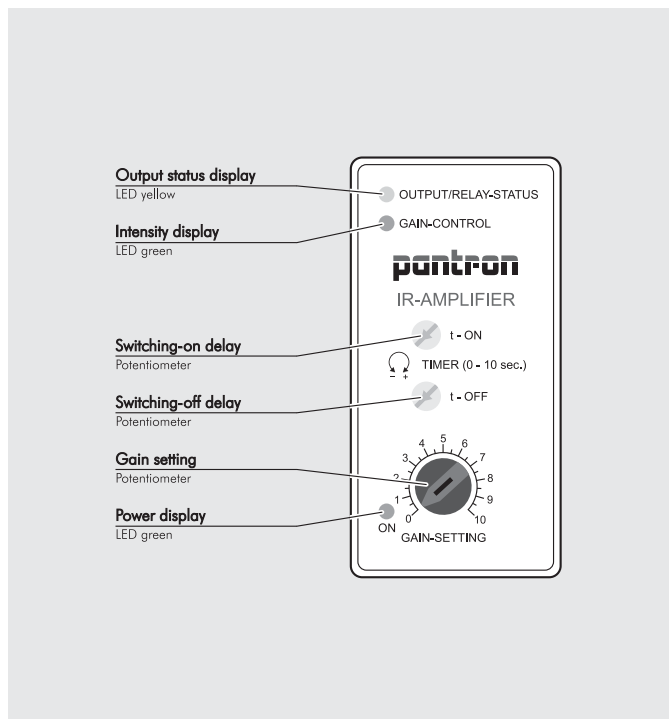
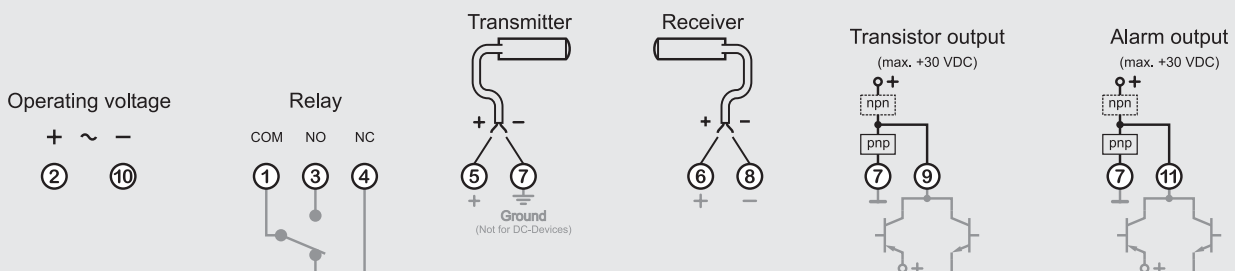

Amplifier mode (Factory setting is marked in white)



1		2		3		4	
Basic transmit level		Switching behaviour		Transmit frequency			
low	ON	dark	ON	3,5 kHz	ON	ON	
				3,8 kHz	ON	OFF	
high	OFF	light	OFF	4,0 kHz	OFF	ON	
				4,4 kHz	OFF	OFF	

1-channel measurement Amplifier ISG-N124M

- Sensor adjustment via analog output
- Detection range up to 55 m
- Sensitivity adjustable with potentiometer
- Sensor control
- Basic transmit level 2-fold selectable
- Switching behaviour light / dark selectable
- Analog output voltage 0-10V / 10-0V selectable
- Transmit frequency 2-fold selectable
- Relay output, change over
- Transistor output, pnp / npn
- Test input for system check

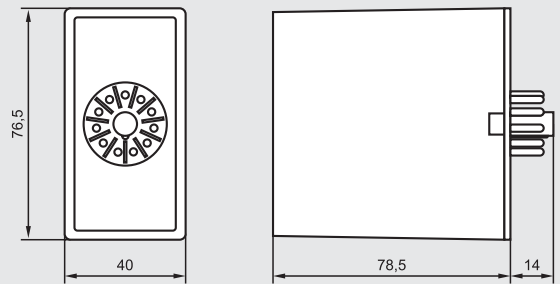

in mm

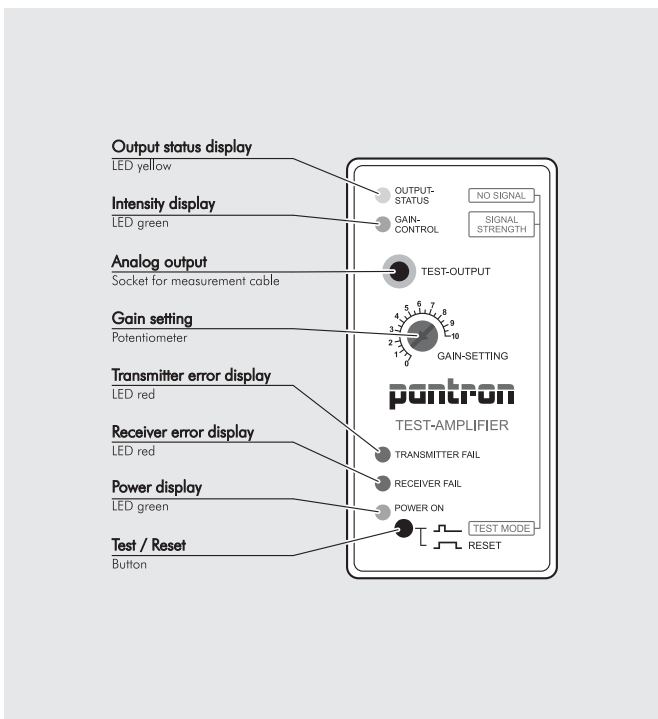

Technical data (at +20°C)

Operating voltage	see purchase order table
Operating basis	modulated infrared light
Transmit frequency	3,5 kHz / 4,4 kHz
Transmit power	manual
Switching behaviour	light / dark
Basic transmit level	low / high
Switching delay	-
Switching output relay	change over, 5 A / 230 V AC (24 V DC)
reaction time	36 ms
Switching output transistor...AC	nnp, 100 mA/30 V DC; pnp, 5mA/12 V DC
...DC	nnp / pnp, 100 mA / 30 V DC
reaction time	36 ms
Analog output	0 ... 10 V DC
Test input	24 V DC
Housing material	plastic
Protection class	IP 40
Connection	11-pin DIN-plug
Operation temperature	-25 °C ... +50 °C

Purchase order table

Operating voltage	Order table
230 V AC / ±10 % / 4,2 VA	ISG-N124M/230VAC
115 V AC / ±10 % / 4,2 VA	ISG-N124M/115VAC
24 V AC / ±10 % / 4,2 VA	ISG-N124M/24VAC
24 V DC / ±20 % / 2,0 W	ISG-N124M/24VDC

Accessories

11-pole DIN-socket	ISO1
Measurement cable	CAB-TEST-4m

Maximum Range

	Receiver IRL...	Receiver IR...
Transmitter IT-..., ITL-...	10 m	20 m
Transmitter IT-...HR..., ITH-...	20 m	35 m
Transmitter ITA-...	35 m	55 m

Amplifier mode (Factory setting is marked in white)



	1	2	3	4
Basic transmit level	low	high	low	high
Switching behaviour	dark	light	dark	light
Analog output	0-10 V	10-0 V	0-10 V	10-0 V
Transmit frequency	3,5 kHz	4,4 kHz	3,5 kHz	4,4 kHz

Connection diagram

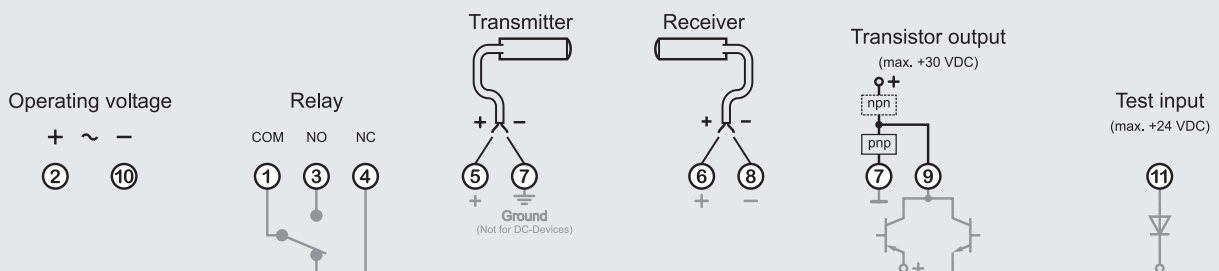

ISG-Series

1-channel Amplifier ISG-N127

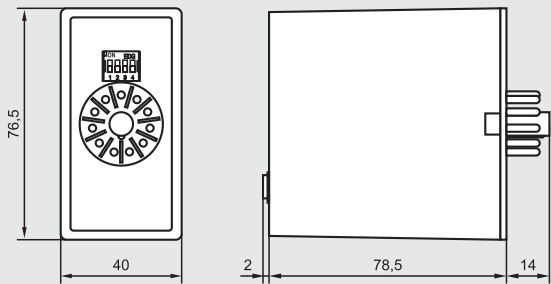

in mm

- Detection range up to 55 m
- Sensitivity adjustable with potentiometer
- Sensor control
- Basic transmit level 2-fold selectable
- Switching behaviour light / dark selectable
- Transmit frequency 4-fold selectable
- Transistor output, pnp / npn
- Alarm output

Technical data (at +20°C)

Operating voltage	see purchase order table
Operating basis	modulated infrared light
Transmit frequency [kHz]	3,0 / 3,3 / 3,7 / 4,0
Transmit power	manual
Switching behaviour	light / dark
Basic transmit level	low / high
Switching delay	-
Switching output relay	-
reaction time	-
Switching output transistor	npn / pnp, 100 mA / 30 V DC
reaction time	Basic transmit level low (high): 16 ms (70 ms)
Alarm output ...AC	npn, 100 mA / 30 V DC
...DC	npn / pnp, 100 mA / 30 V DC
Test input	-
Housing material	plastic
Protection class	IP 40
Connection	11-pin DIN-plug
Operation temperature	-25 °C ... +50 °C

Purchase order table

Operating voltage	Order table
230 V AC / ±10 % / 4,2VA	ISG-N127/230VAC
115 V AC / ±10 % / 4,2 VA	ISG-N127/115VAC
24 V AC / ±10 % / 4,2 VA	ISG-N127/24VAC
24 V DC / ±20 % / 1,7 W	ISG-N127/24VDC

Accessories

11-pole DIN-socket	ISO1
Protective enclosure	PanBox 1x1

Maximum Range

	Receiver IRL-...	Receiver IR-...
Transmitter IT-..., ITL-...	10 m	20 m
Transmitter IT-...HP..., ITH-...	20 m	35 m
Transmitter ITA-...	35 m	55 m

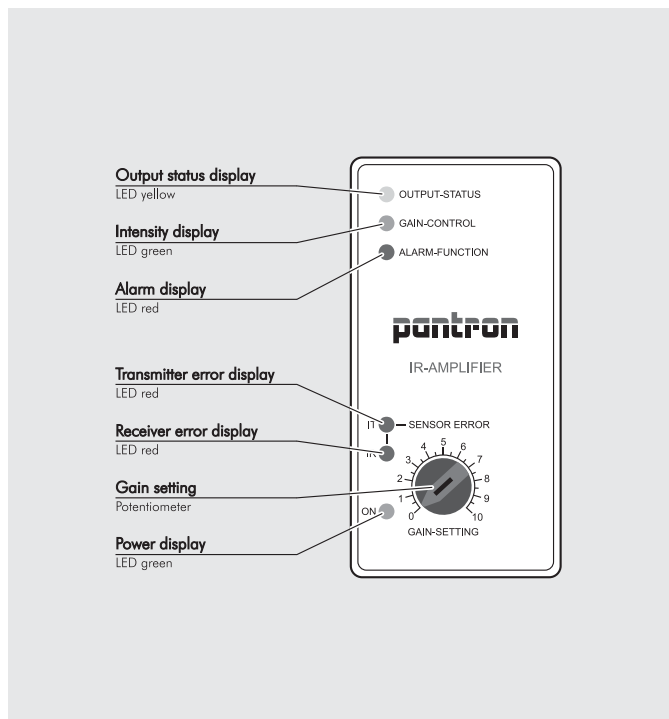

Amplifier mode (Factory setting is marked in white)



1		2		3		4	
Basic transmit level		Switching behaviour		Transmit frequency			
low	ON	dark	ON	3,0 kHz	ON	ON	
				3,3 kHz	ON	OFF	
high	OFF	light	OFF	3,7 kHz	OFF	ON	
				4,0 kHz	OFF	OFF	

Connection diagram

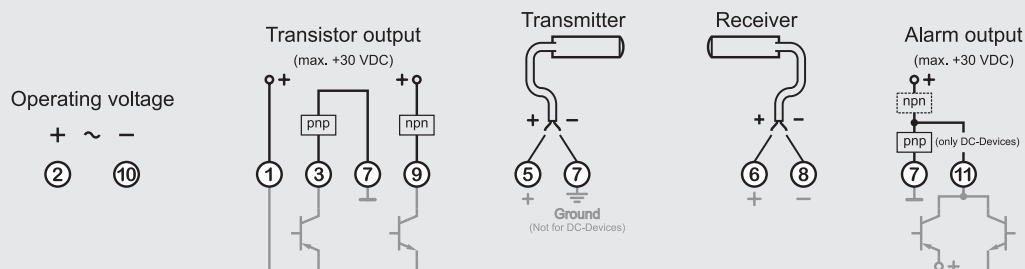

1-channel Amplifier ISG-N128

- Detection range up to 55 m
- Sensitivity adjustable with potentiometer
- Sensor control
- Basic transmit level 2-fold selectable
- Switching behaviour light / dark selectable
- Transmit frequency 4-fold selectable
- Relay output, change over
- Transistor output, npn
- Alarm output

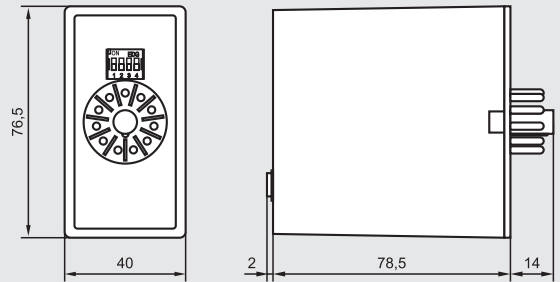

in mm

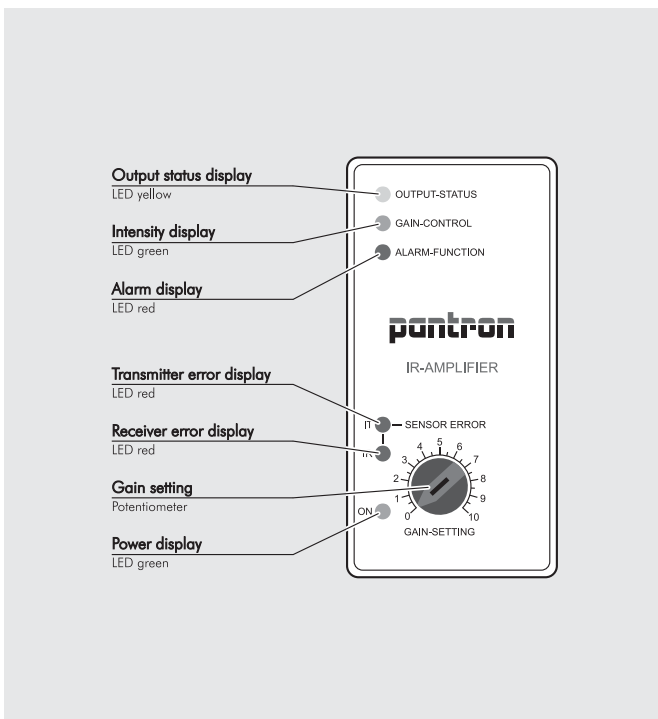

Technical data (at +20°C)

Operating voltage	see purchase order table
Operating basis	modulated infrared light
Transmit frequency [kHz]	3,0 / 3,3 / 3,7 / 4,0
Transmit power	manual
Switching behaviour	light / dark
Basic transmit level	low / high
Switching delay	-
Switching output relay	change over, 5 A / 230 V AC (24 V DC)
reaction time	Basic transmit level low (high): 16 ms (70 ms)
Switching output transistor	npn, 100 mA / 30 V DC
reaction time	Basic transmit level low (high): 16 ms (70 ms)
Alarm output ...AC	npn, 100 mA / 30 V DC
...DC	npn / pnp, 100 mA / 30 V DC
Test input	-
Housing material	plastic
Protection class	IP 40
Connection	11-pin DIN-plug
Operation temperature	-25 °C ... +50 °C

Purchase order table

Operating voltage	Order table
230 V AC / ±10 % / 4,2VA	ISG-N128/230VAC
115 V AC / ±10 % / 4,2 VA	ISG-N128/115VAC
24 V AC / ±10 % / 4,2 VA	ISG-N128/24VAC
24 V DC / ±20 % / 1,7 W	ISG-N128/24VDC

Accessories

11-pole DIN-socket	ISO1
Protective enclosure	PanBox 1x1

Maximum Range

	Receiver IRL-...	Receiver IR-...
Transmitter IT-..., ITL-...	10 m	20 m
Transmitter IT-...HR..., ITH-...	20 m	35 m
Transmitter ITA-...	35 m	55 m

Amplifier mode (Factory setting is marked in white)



1		2		3		4	
Basic transmit level		Switching behaviour		Transmit frequency			
low	ON	dark	ON	3,0 kHz	ON	ON	
				3,3 kHz	ON	OFF	
high	OFF	light	OFF	3,7 kHz	OFF	ON	
				4,0 kHz	OFF	OFF	

Connection diagram

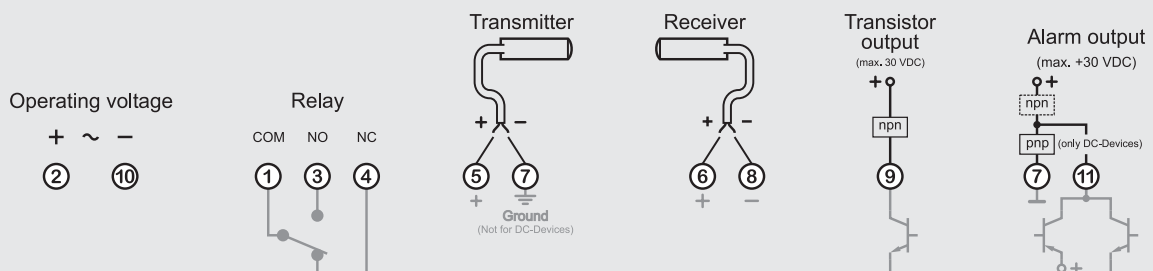

ISG-Series

1-channel Amplifier ISG-N137

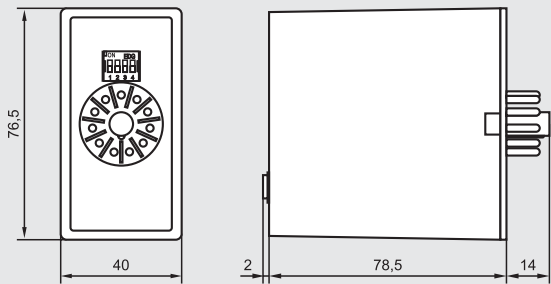

in mm

- Detection range up to 55 m
- Sensitivity adjustable with potentiometer
- Sensor control
- Basic transmit level 2-fold selectable
- Switching behaviour light / dark selectable
- Transmit frequency 4-fold selectable
- Switching delay
- Transistor output, pnp / npn
- Alarm output

Technical data (at +20°C)

Operating voltage	see purchase order table
Operating basis	modulated infrared light
Transmit frequency [kHz]	3,0 / 3,3 / 3,7 / 4,0
Transmit power	manual
Switching behaviour	light / dark
Basic transmit level	low / high
Switching delay	0 ... 10 s
Switching output relay	-
reaction time	
Switching output transistor	npn / pnp, 100 mA / 30 V DC
reaction time	Basic transmit level low (high): 16 ms (70 ms)
Alarm output ...AC	npn, 100 mA / 30 V DC
...DC	npn / pnp, 100 mA / 30 V DC
Test input	-
Housing material	plastic
Protection class	IP 40
Connection	11-pin DIN-plug
Operation temperature	-25 °C ... +50 °C

Purchase order table

Operating voltage	Order table
230 V AC / ±10 % / 4,2VA	ISG-N137/230VAC
115 V AC / ±10 % / 4,2 VA	ISG-N137/115VAC
24 V AC / ±10 % / 4,2 VA	ISG-N137/24VAC
24 V DC / ±20 % / 1,7 W	ISG-N137/24VDC

Accessories

11-pole DIN-socket	ISO1
Protective enclosure	PanBox 1x1

Maximum Range

	Receiver IRL-...	Receiver IR-...
Transmitter IT-..., ITL-...	10 m	20 m
Transmitter IT-...HR..., ITH-...	20 m	35 m
Transmitter ITA-...	35 m	55 m

Connection diagram

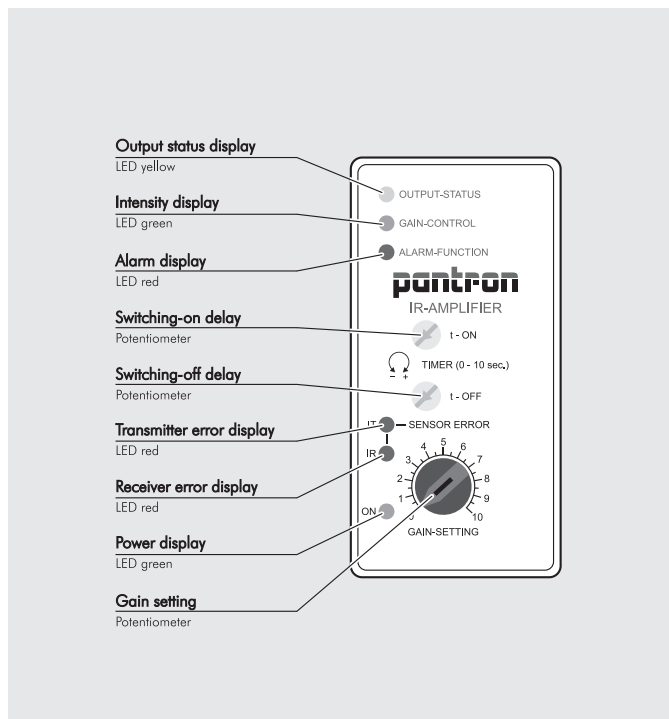
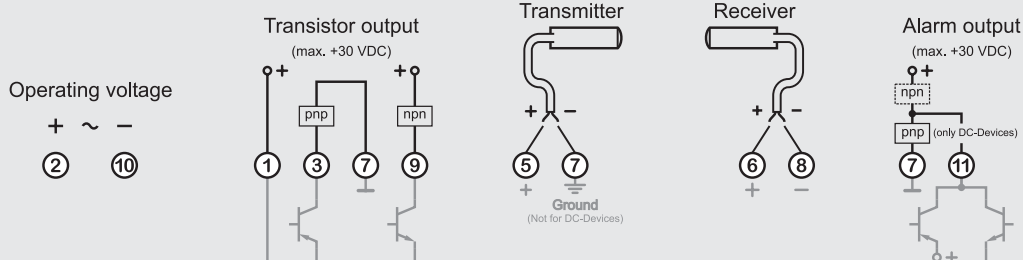

Amplifier mode (Factory setting is marked in white)



		1	2	3		4	
		Basic transmit level		Switching behaviour		Transmit frequency	
low	ON	dark	ON	3,0 kHz	ON	ON	
	OFF	light	OFF	3,3 kHz	ON	OFF	
high	ON	dark	ON	3,7 kHz	OFF	ON	
	OFF	light	OFF	4,0 kHz	OFF	OFF	

1-channel Amplifier ISG-N138

- Detection range up to 55 m
- Sensitivity adjustable with potentiometer
- Sensor control
- Basic transmit level 2-fold selectable
- Switching behaviour light / dark selectable
- Transmit frequency 4-fold selectable
- Switching delay
- Relay output, change over
- Transistor output, npn
- Alarm output

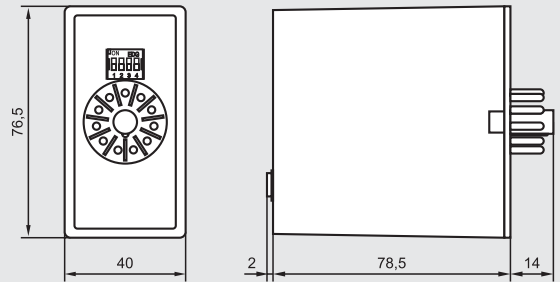

in mm

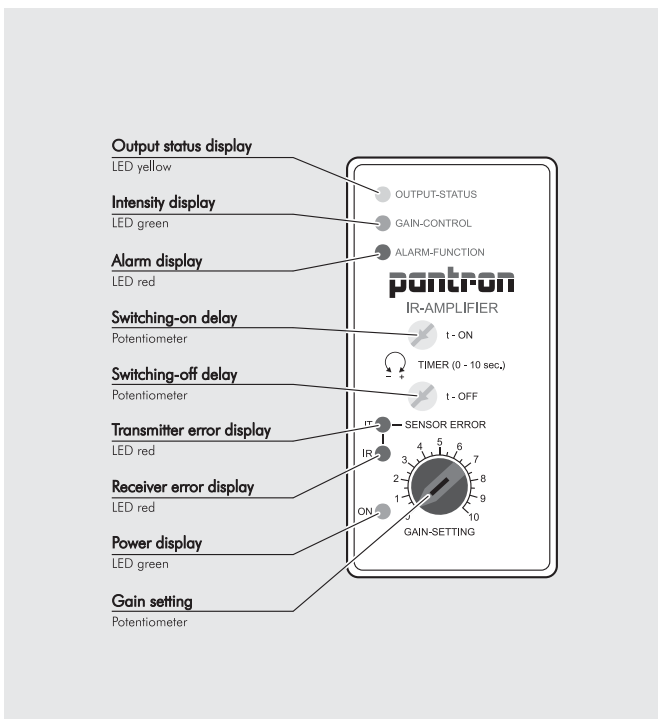

Technical data (at +20°C)

Operating voltage	see purchase order table
Operating basis	modulated infrared light
Transmit frequency [kHz]	3,0 / 3,3 / 3,7 / 4,0
Transmit power	manual
Switching behaviour	light / dark
Basic transmit level	low / high
Switching delay	0 ... 10 s
Switching output relay	change over, 5 A / 230 V AC (24 V DC)
reaction time	Basic transmit level low (high): 16 ms (70 ms)
Switching output transistor	nnp, 100 mA / 30 V DC
reaction time	Basic transmit level low (high): 16 ms (70 ms)
Alarm output ...AC	nnp, 100 mA / 30 V DC
...DC	nnp / pnp, 100 mA / 30 V DC
Test input	-
Housing material	plastic
Protection class	IP 40
Connection	11-pin DIN-plug
Operation temperature	-25 °C ... +50 °C

Purchase order table

Operating voltage	Order table
230 V AC / ±10 % / 4,2VA	ISG-N138/230VAC
115 V AC / ±10 % / 4,2 VA	ISG-N138/115VAC
24 V AC / ±10 % / 4,2 VA	ISG-N138/24VAC
24 V DC / ±20 % / 1,7 W	ISG-N138/24VDC

Accessories

11-pole DIN-socket	ISO1
Protective enclosure	PanBox 1x1

Maximum Range

	Receiver IRL-...	Receiver IR-...
Transmitter IT-..., ITL-...	10 m	20 m
Transmitter IT-...HR..., ITH-...	20 m	35 m
Transmitter ITA-...	35 m	55 m

Amplifier mode (Factory setting is marked in white)



1		2		3		4	
Basic transmit level		Switching behaviour		Transmit frequency			
low	ON	dark	ON	3,0 kHz	ON	ON	
				3,3 kHz	ON	OFF	
high	OFF	light	OFF	3,7 kHz	OFF	ON	
				4,0 kHz	OFF	OFF	

Connection diagram

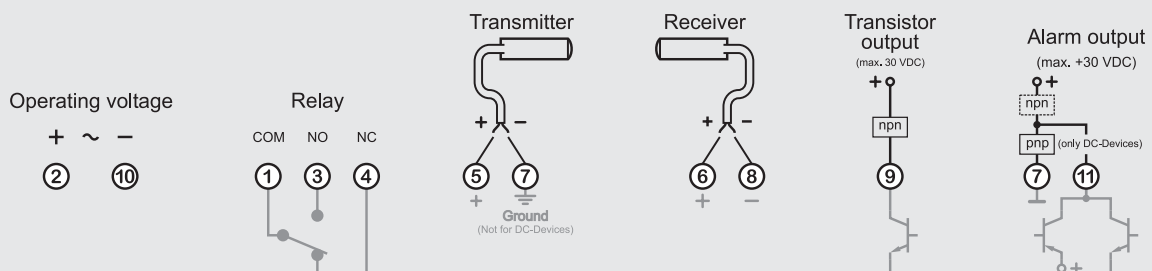

ISG-Series

1-channel automatic Amplifier **ISG-A113**

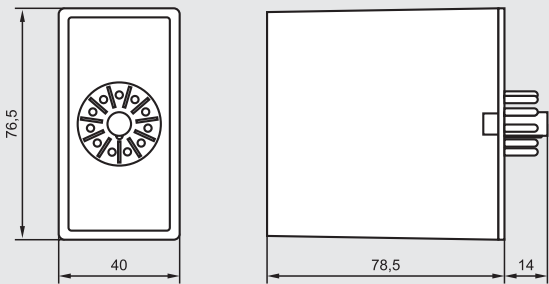

in mm

- Detection range up to 50 m
- Automatic transmit power adjustment
- Basic transmit level 2-fold selectable
- Transistor output, pnp / npn
- Alarm output

Technical data (at +20°C)

Operating voltage	see purchase order table
Operating basis	modulated infrared light
Transmit frequency	3,9 kHz
Transmit power	automatic
Switching behaviour	light
Basic transmit level	low1 / low2
Switching delay	-
Teach function	-
Switching output relay	-
reaction time	-
Switching output transistor	nnp / pnp, 100 mA / 30 V DC
reaction time	25 ms
Alarm output ...AC	pnp, 5 mA / 24 V DC
...DC	pnp, 100 mA / 24 V DC
Test input	-
Housing material	plastic
Protection class	IP 40
Connection	11-pin DIN-plug
Operation temperature	-25 °C ... +50 °C

Purchase order table

Operating voltage	Order table
230 V AC / ±10 % / 4,6VA	ISG-A113/230VAC
115 V AC / ±10 % / 4,6 VA	ISG-A113/115VAC
24 V AC / ±10 % / 4,6 VA	ISG-A113/24VAC
24 V DC / ±20 % / 2,1 W	ISG-A113/24VDC

Accessories

11-pole DIN-socket	ISO1
Protective enclosure	PanBox 1x1

Maximum Range

	Receiver IRL-...	Receiver IR-...
Transmitter IT-..., ITL-...	7 m	15 m
Transmitter IT-...HP..., ITH-...	10 m	25 m
Transmitter ITA-...	20 m	50 m

Connection diagram

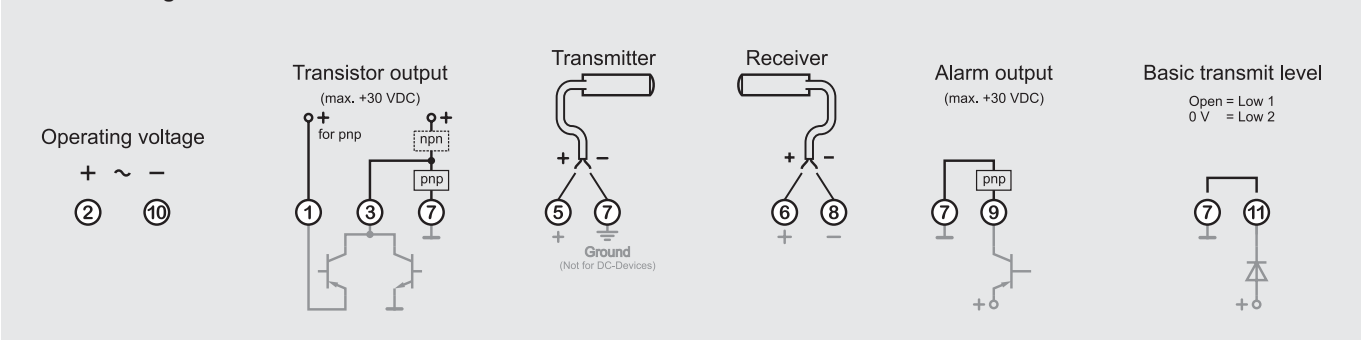

1-channel automatic Amplifier **ISG-A114**

- Detection range up to 50 m
- Automatic transmit power adjustment
- Basic transmit level 2-fold selectable
- Relay output, change over
- Alarm output

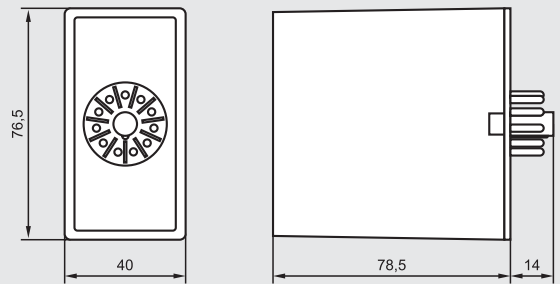

in mm

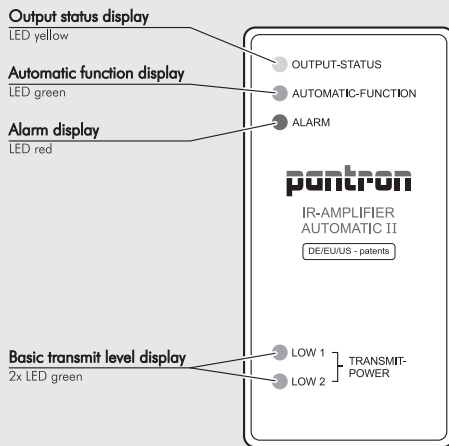

Technical data (at +20°C)

Operating voltage	see purchase order table
Operating basis	modulated infrared light
Transmit frequency	3,9 kHz
Transmit power	automatic
Switching behaviour	light
Basic transmit level	low1 / low2
Switching delay	-
Teach function	-
Switching output relay	change over, 5 A / 230 V AC (24 V DC)
reaction time	25 ms
Switching output transistor	-
reaction time	-
Alarm output ...AC	pnp, 5 mA / 24 V DC
...DC	pnp, 100 mA / 24 V DC
Test input	-
Housing material	plastic
Protection class	IP 40
Connection	11-pin DIN-plug
Operation temperature	-25 °C ... +50 °C

Purchase order table

Operating voltage	Order table
230 V AC / ±10 % / 4,6VA	ISG-A114/230VAC
115 V AC / ±10 % / 4,6 VA	ISG-A114/115VAC
24 V AC / ±10 % / 4,6 VA	ISG-A114/24VAC
24 V DC / ±20 % / 2,1 W	ISG-A114/24VDC

Accessories

11-pole DIN-socket	ISO1
Protective enclosure	PanBox 1x1

Maximum Range

	Receiver IRL-...	Receiver IR-...
Transmitter IT-..., ITL-...	7 m	15 m
Transmitter IT-...HR..., ITH-...	10 m	25 m
Transmitter ITA-...	20 m	50 m

Connection diagram

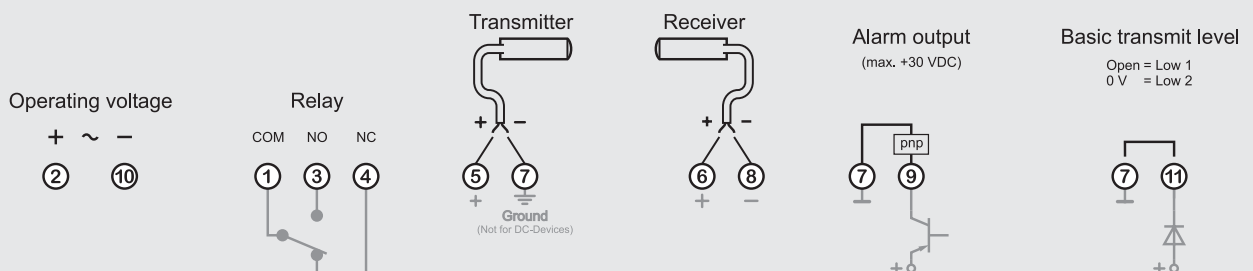

1-channel automatic Amplifier **ISG-A124**

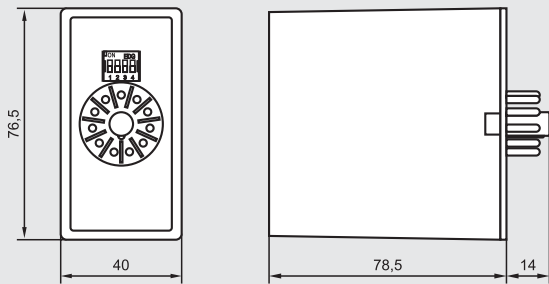

in mm

- Detection range up to 50 m
- Automatic transmit power adjustment
- Test function
- Basic transmit level 4-fold selectable
- Switching behaviour light / dark selectable
- Transmit frequency 4-fold selectable
- Relay output, change over
- Alarm output
- Test input for system check

Technical data (at +20°C)

Operating voltage	see purchase order table
Operating basis	modulated infrared light
Transmit frequency	3,9 kHz / 4,1 kHz
Transmit power	automatic
Switching behaviour	light / dark
Basic transmit level	low1 / low2 / high1 / high2
Switching delay	-
Teach function	-
Switching output relay	change over, 5 A / 230 V AC (24 V DC)
reaction time	Basic transmit level low (high): 25 ms (52 ms)
Switching output transistor	-
reaction time	-
Alarm output ...AC	pnp, 5 mA / 24 V DC
...DC	pnp, 100 mA / 24 V DC
Test input	0 ... 30 V DC
Housing material	plastic
Protection class	IP 40
Connection	11-pin DIN-plug
Operation temperature	-25 °C ... +50 °C

Purchase order table

Operating voltage	Order table
230 V AC / ±10 % / 4,8VA	ISG-A124/230VAC
115 V AC / ±10 % / 4,8 VA	ISG-A124/115VAC
24 V AC / ±10 % / 4,8 VA	ISG-A124/24VAC
24 V DC / ±20 % / 2,2 W	ISG-A124/24VDC

Accessories

11-pole DIN-socket	ISO1
Protective enclosure	PanBox 1x1

Maximum Range

	Receiver IRL-...	Receiver IR-...
Transmitter IT-..., ITL-...	7 m	15 m
Transmitter IT-...HP-..., ITH-...	10 m	25 m
Transmitter ITA-...	20 m	50 m

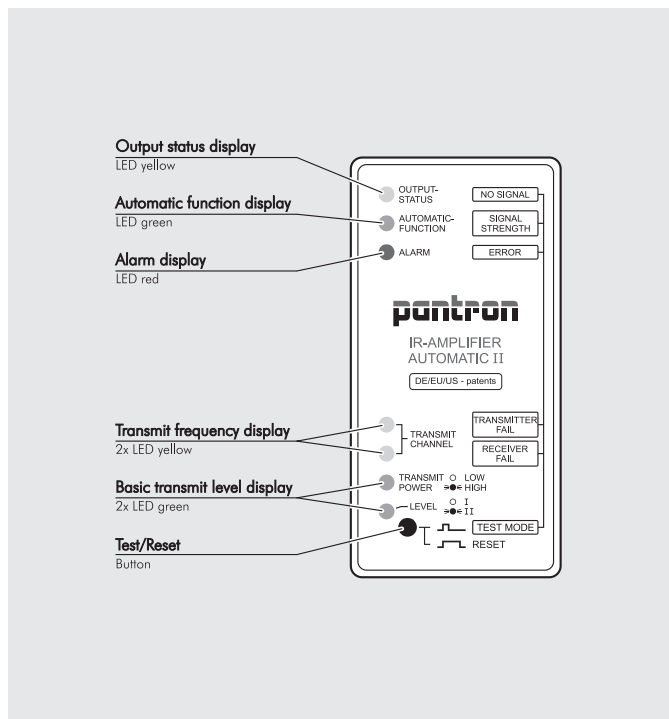

Amplifier mode (Factory setting is marked in white)



	1	2	3	4		
Basic transmit level	Switching behaviour		Transmit frequency			
high2	ON	ON	dark	ON	4,1 kHz	ON
high1	ON	OFF	light	OFF	3,7 kHz	OFF
low2	OFF	ON				
low1	OFF	OFF				

Connection diagram

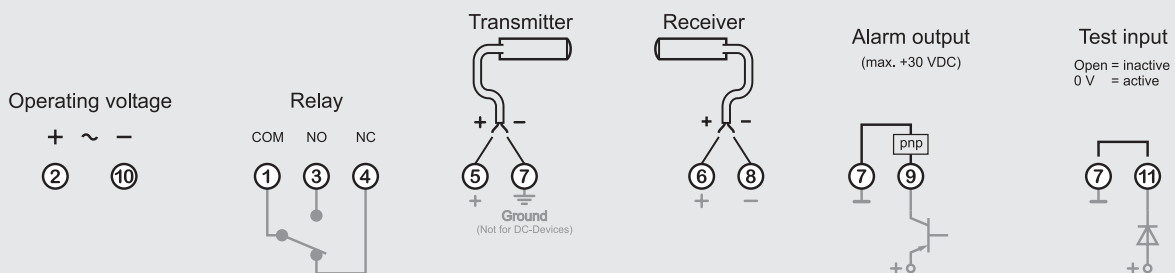

1-channel automatic Amplifier **ISG-A134**

- Detection range up to 50 m
- Automatic transmit power adjustment
- Test function
- Basic transmit level 4-fold selectable
- Switching behaviour light / dark selectable
- Transmit frequency 4-fold selectable
- Switching delay
- Relay output, change over
- Alarm output
- Test input for system check

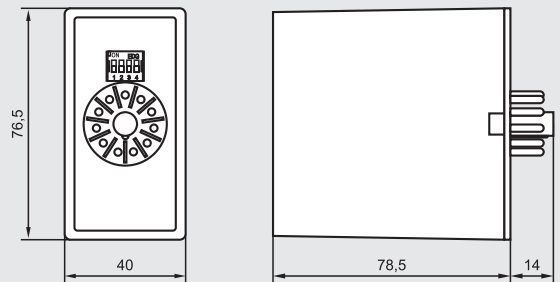

in mm

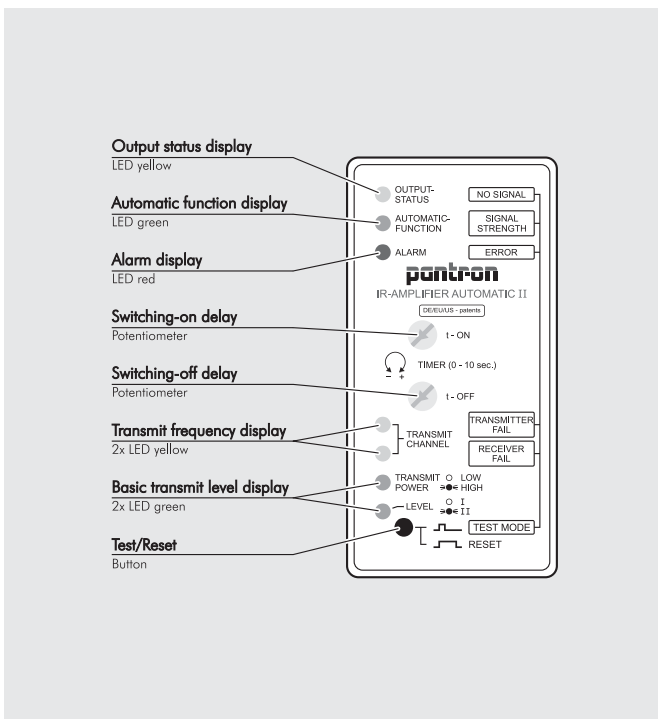

Technical data (at +20°C)

Operating voltage	see purchase order table
Operating basis	modulated infrared light
Transmit frequency	3,9 kHz / 4,1 kHz
Transmit power	automatic
Switching behaviour	light / dark
Basic transmit level	low1 / low2 / high1 / high2
Switching delay	0 ... 10 s
Teach function	-
Switching output relay	change over, 5 A / 230 V AC (24 V DC)
reaction time	Basic transmit level low (high): 25 ms (52 ms)
Switching output transistor	-
reaction time	-
Alarm output ...AC	pnp, 5 mA / 24 V DC
...DC	pnp, 100 mA / 24 V DC
Test input	0 ... 30 V DC
Housing material	plastic
Protection class	IP 40
Connection	11-pin DIN-plug
Operation temperature	-25 °C ... +50 °C

Purchase order table

Operating voltage	Order table
230 V AC / ±10 % / 4,8VA	ISG-A134/230VAC
115 V AC / ±10 % / 4,8 VA	ISG-A134/115VAC
24 V AC / ±10 % / 4,8 VA	ISG-A134/24VAC
24 V DC / ±20 % / 2,2 W	ISG-A134/24VDC

Accessories

11-pole DIN-socket	ISO1
Protective enclosure	PanBox 1x1

Maximum Range

	Receiver IRL-...	Receiver IR-...
Transmitter IT-..., ITL-...	7 m	15 m
Transmitter IT-...HR..., ITH-...	10 m	25 m
Transmitter ITA-...	20 m	50 m

Amplifier mode (Factory setting is marked in white)



	1	2	3	4
Basic transmit level				
high2	ON	ON	dark	ON
high1	ON	OFF	light	OFF
low2	OFF	ON		
low1	OFF	OFF		

Connection diagram

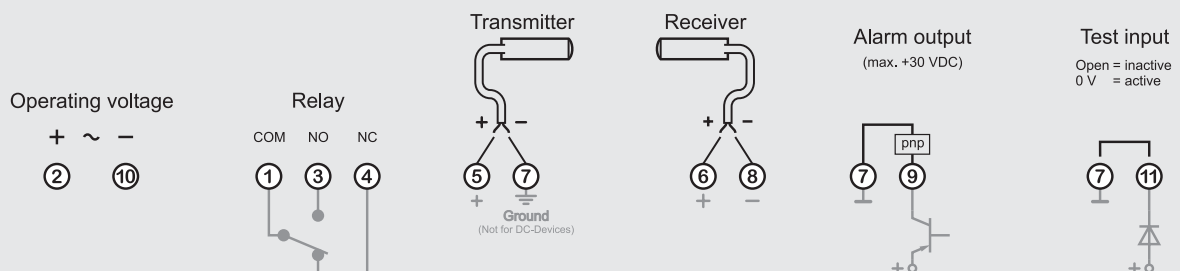

1-channel automatic Amplifier **ISG-A143**

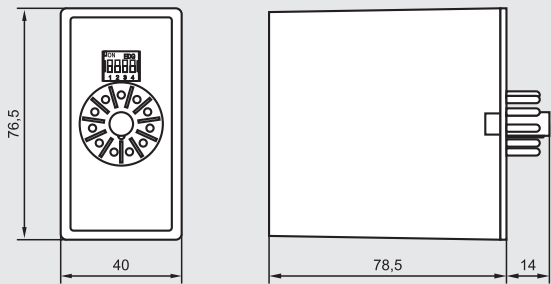

in mm

- Detection range up to 50 m
- Automatic transmit power adjustment
- Teach function
- Test function
- Basic transmit level 2-fold selectable
- Switching behaviour light / dark selectable
- Transmit frequency 2-fold selectable
- Transistor output, pnp / npn
- Alarm output
- Test input for system check

Technical data (at +20°C)

Operating voltage	see purchase order table
Operating basis	modulated infrared light
Transmit frequency	3,9 kHz / 4,1 kHz
Transmit power	automatic
Switching behaviour	light / dark
Basic transmit level	low1 / low2
Switching delay	-
Teach function	teach1 / teach2
Switching output relay	-
reaction time	
Switching output transistor	pnp / npn, 100 mA / 30 V DC
reaction time	25 ms
Alarm output ...AC	pnp, 5 mA / 24 V DC
...DC	pnp, 100 mA / 24 V DC
Test input	0 ... 30 V DC
Housing material	plastic
Protection class	IP 40
Connection	11-pin DIN-plug
Operation temperature	-25 °C ... +50 °C

Purchase order table

Operating voltage	Order table
230 V AC / ±10 % / 4,6 VA	ISG-A143/230VAC
115 V AC / ±10 % / 4,6 VA	ISG-A143/115VAC
24 V AC / ±10 % / 4,6 VA	ISG-A143/24VAC
24 V DC / ±20 % / 2,1 W	ISG-A143/24VDC

Accessories

11-pole DIN-socket	ISO1
Protective enclosure	PanBox 1x1

Maximum Range

	Receiver IRL-...	Receiver IR-...
Transmitter IT-..., ITL-...	7 m	15 m
Transmitter IT-...HP-..., ITH-...	10 m	25 m
Transmitter ITA-...	20 m	50 m

Connection diagram

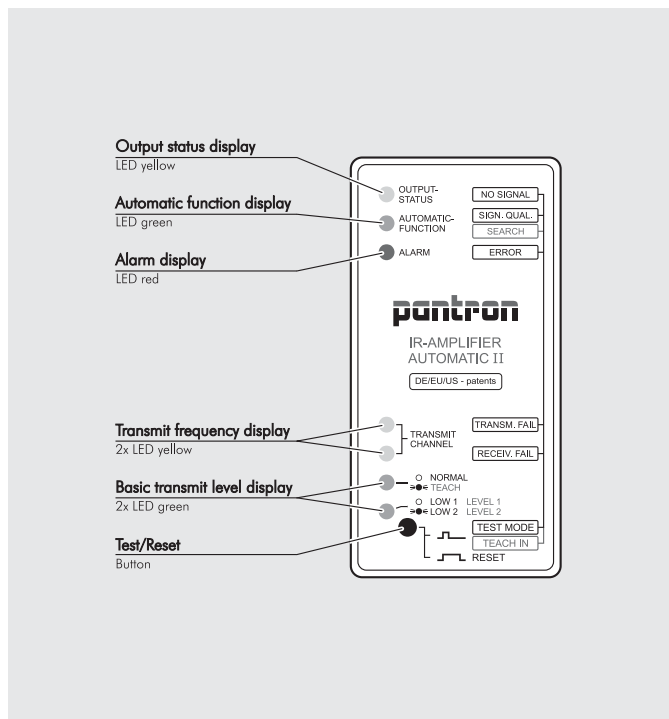
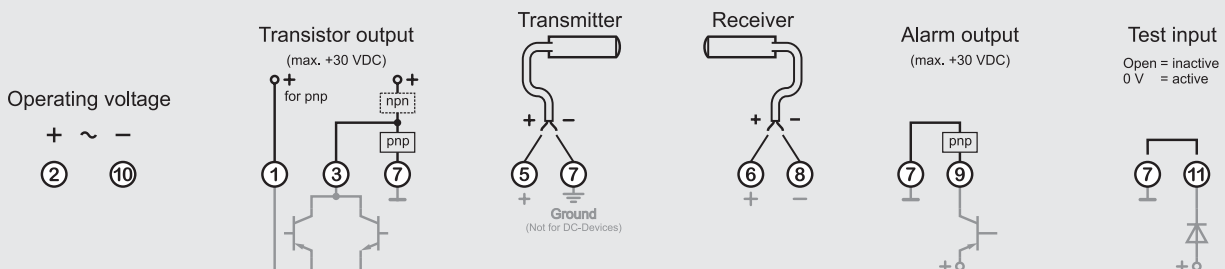

Amplifier mode (Factory setting is marked in white)



	1	2	3	4
Operation mode			Switching behaviour	Transmit frequency
teach2	ON	ON	dark	ON
teach1	ON	OFF	ON	4,1 kHz
low2	OFF	ON	light	OFF
low1	OFF	OFF	OFF	3,7 kHz

1-channel automatic Amplifier ISG-A144

- Detection range up to 50 m
- Automatic transmit power adjustment
- Teach function
- Test function
- Basic transmit level 2-fold selectable
- Switching behaviour light / dark selectable
- Transmit frequency 2-fold selectable
- Relay output, change over
- Alarm output
- Test input for system check

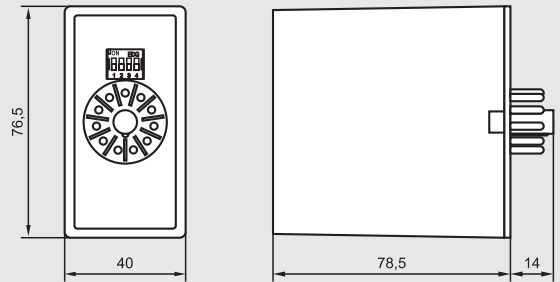

in mm

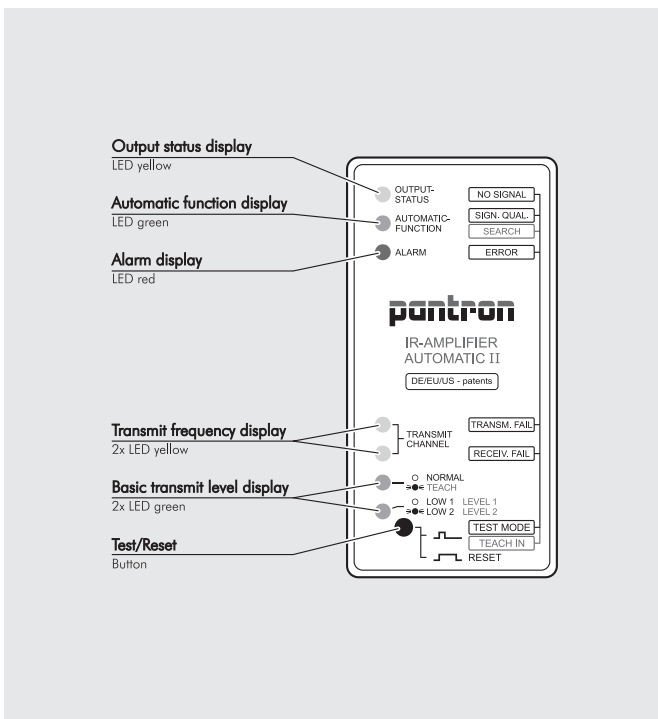

Technical data (at +20°C)

Operating voltage	see purchase order table
Operating basis	modulated infrared light
Transmit frequency	3,9 kHz / 4,1 kHz
Transmit power	automatic
Switching behaviour	light / dark
Basic transmit level	low1 / low2
Switching delay	-
Teach function	teach1 / teach2
Switching output relay	change over, 5 A / 230 V AC (24 V DC)
reaction time	25 ms
Switching output transistor	-
reaction time	-
Alarm output ...AC	pnp, 5 mA / 24 V DC
...DC	pnp, 100 mA / 24 V DC
Test input	0 ... 30 V DC
Housing material	plastic
Protection class	IP 40
Connection	11-pin DIN-plug
Operation temperature	-25 °C ... +50 °C

Purchase order table

Operating voltage	Order table
230 V AC / ±10 % / 4,8 VA	ISG-A144/230VAC
115 V AC / ±10 % / 4,8 VA	ISG-A144/115VAC
24 V AC / ±10 % / 4,8 VA	ISG-A144/24VAC
24 V DC / ±20 % / 2,2 W	ISG-A144/24VDC

Accessories

11-pole DIN-socket	ISO1
Protective enclosure	PanBox 1x1

Maximum Range

	Receiver IRL-...	Receiver IR-...
Transmitter IT-..., ITL-...	7 m	15 m
Transmitter IT-...HR..., ITH-...	10 m	25 m
Transmitter ITA-...	20 m	50 m

Amplifier mode (Factory setting is marked in white)



	1	2	3		4	
Operation mode			Switching behaviour		Transmit frequency	
teach2	ON	ON	dark	ON	4,1 kHz	ON
teach1	ON	OFF	light	OFF	3,7 kHz	OFF
low2	OFF	ON				
low1	OFF	OFF				

Connection diagram

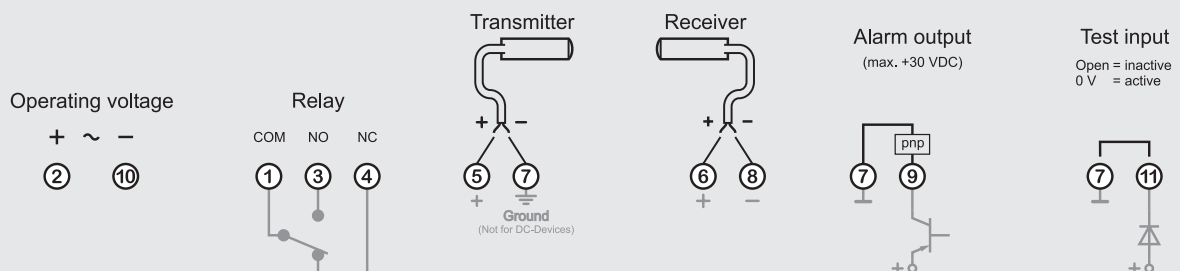

IMX-Series

1-channel multiplex Amplifier **IMX-N23**

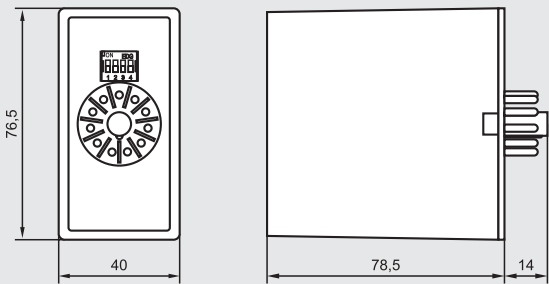

in mm

- Detection range up to 50 m
- Sensitivity adjustable with potentiometer
- Basic transmit level 2-fold selectable
- Switching behaviour light / dark selectable
- Multiplex speed 2-fold selectable
- Transistor output, pnp / npn

Technical data (at +20°C)

Operating voltage	see purchase order table
Operating basis	modulated infrared light
Transmit frequency	4,0 kHz
Transmit power	manual
Switching behaviour	light / dark
Basic transmit level	low / high
Multiplex speed	8 ms / 16 ms
Switching delay	-
Light curtain	-
Master-Slave	-
Switching output	Transistor, 2x pnp / npn
max. operation value	100 mA / 30 V DC
reaction time	Multiplex speed 8 ms (16 ms): 16 ms (32 ms)
Alarm output	-
Test input	-
Housing material	plastic
Protection class	IP 40
Connection	11-pin DIN-plug
Operation temperature	-25 °C ... +50 °C

Purchase order table

Operating voltage	Order table
230 V AC / ±10 % / 4,1 VA	IMX-N23/230VAC
115 V AC / ±10 % / 4,1 VA	IMX-N23/115VAC
24 V AC / ±10 % / 4,1 VA	IMX-N23/24VAC
24 V DC / ±20 % / 2,0 W	IMX-N23/24VDC

Accessories

11-pole DIN-socket	ISO1
Protective enclosure	PanBox 1x2

Maximum Range

	Receiver IRL-...	Receiver IR-...
Transmitter IT-..., ITL-...	10 m	20 m
Transmitter IT-...HP..., ITH-...	15 m	30 m
Transmitter ITA-...	25 m	50 m

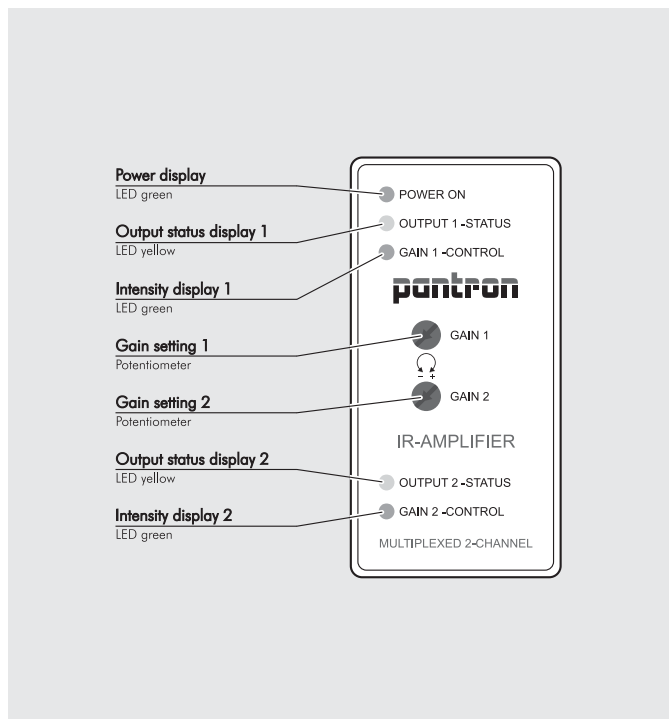

Amplifier mode (Factory setting is marked in white)



1		2		3		4	
Switching behaviour channel 1		Switching behaviour channel 2		Basic transmit level		Multiplex speed	
dark	ON	dark	ON	high	ON	16 ms	ON
light	OFF	light	OFF	low	OFF	8 ms	OFF

Connection diagram

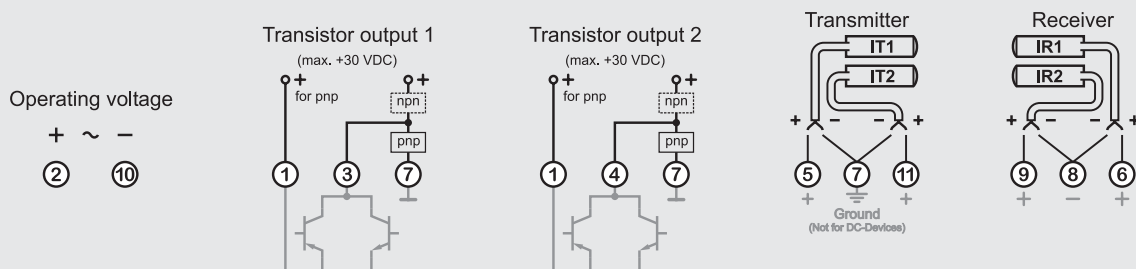

1-channel multiplex Amplifier **IMX-N24**

- Detection range up to 50 m
- Sensitivity adjustable with potentiometer
- Basic transmit level 2-fold selectable
- Switching behaviour light / dark selectable
- Multiplex speed 2-fold selectable
- Relay output, normally open

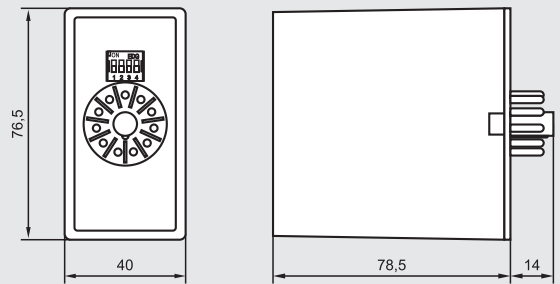

in mm

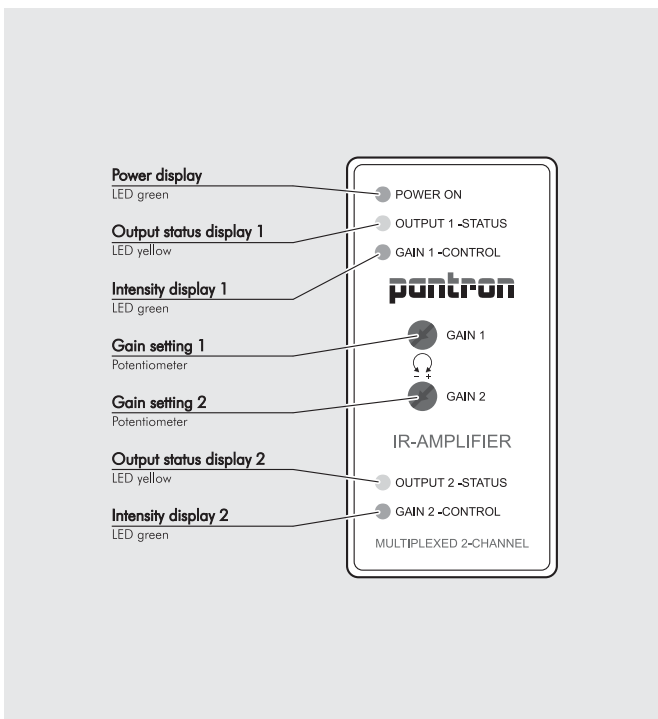

Technical data (at +20°C)

Operating voltage	see purchase order table
Operating basis	modulated infrared light
Transmit frequency	4,0 kHz
Transmit power	manual
Switching behaviour	light / dark
Basic transmit level	low / high
Multiplex speed	8 ms / 16 ms
Switching delay	-
Light curtain	-
Master-Slave	-
Switching output	Relay, 2x normally open
max. operation value	5 A / 230 V AC (24 V DC)
reaction time	Multiplex speed 8 ms (16 ms): 16 ms (32 ms)
Alarm output	-
Test input	-
Housing material	plastic
Protection class	IP 40
Connection	11-pin DIN-plug
Operation temperature	-25 °C ... +50 °C

Purchase order table

Operating voltage	Order table
230 V AC / ±10 % / 4,1 VA	IMX-N24/230VAC
115 V AC / ±10 % / 4,1 VA	IMX-N24/115VAC
24 V AC / ±10 % / 4,1 VA	IMX-N24/24VAC
24 V DC / ±20 % / 2,0 W	IMX-N24/24VDC

Accessories

11-pole DIN-socket	ISO1
Protective enclosure	PanBox 1x2

Maximum Range

	Receiver IRL-...	Receiver IR-...
Transmitter IT-..., ITL-...	10 m	20 m
Transmitter IT-...HP..., ITH-...	15 m	30 m
Transmitter ITA-...	25 m	50 m

Amplifier mode (Factory setting is marked in white)



1		2		3		4	
Switching behaviour channel 1		Switching behaviour channel 2		Basic transmit level		Multiplex speed	
dark	ON	dark	ON	high	ON	16 ms	ON
light	OFF	light	OFF	low	OFF	8 ms	OFF

Connection diagram

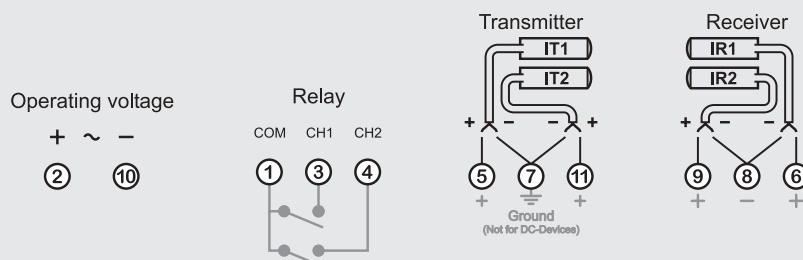

IMX-Series

2-channel multiplex Amplifier **IMX-N33**

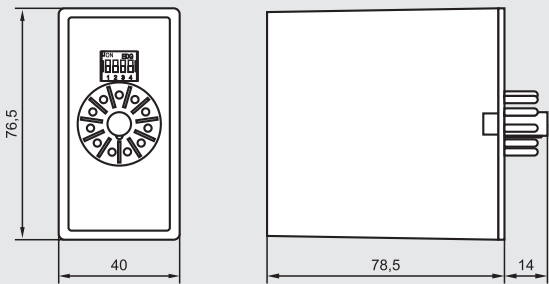

in mm

- Detection range up to 50 m
- Sensitivity adjustable with potentiometer
- Basic transmit level 2-fold selectable
- Switching behaviour light / dark selectable
- Multiplex speed 2-fold selectable
- Switching delay
- Transistor output, pnp / npn

Technical data (at +20°C)

Operating voltage	see purchase order table
Operating basis	modulated infrared light
Transmit frequency	4,0 kHz
Transmit power	manual
Switching behaviour	light / dark
Basic transmit level	low / high
Multiplex speed	8 ms / 16 ms
Switching delay	0 ... 15 s
Light curtain	-
Master-Slave	-
Switching output	Transistor, 2x pnp / npn
max. operation value	100 mA / 30 V DC
reaction time	Multiplex speed 8 ms (16 ms): 16 ms (32 ms)
Alarm output	-
Test input	-
Housing material	plastic
Protection class	IP 40
Connection	11-pin DIN-plug
Operation temperature	-25 °C ... +50 °C

Purchase order table

Operating voltage	Order table
230 V AC / ±10 % / 4,1 VA	IMX-N33/230VAC
115 V AC / ±10 % / 4,1 VA	IMX-N33/115VAC
24 V AC / ±10 % / 4,1 VA	IMX-N33/24VAC
24 V DC / ±20 % / 2,0 W	IMX-N33/24VDC

Accessories

11-pole DIN-socket	ISO1
Protective enclosure	PanBox 1x2

Maximum Range

	Receiver IRL-...	Receiver IR-...
Transmitter IT-..., ITL-...	10 m	20 m
Transmitter IT-...HP..., ITH-...	15 m	30 m
Transmitter ITA-...	25 m	50 m

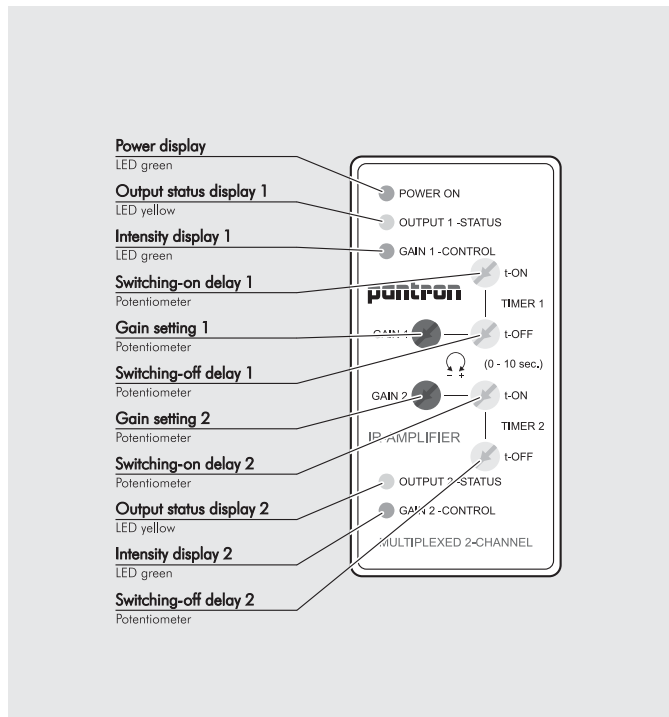

Amplifier mode (Factory setting is marked in white)



1		2		3		4	
Switching behaviour channel 1		Switching behaviour channel 2		Basic transmit level		Multiplex speed	
dark	ON	dark	ON	high	ON	16 ms	ON
light	OFF	light	OFF	low	OFF	8 ms	OFF

Connection diagram

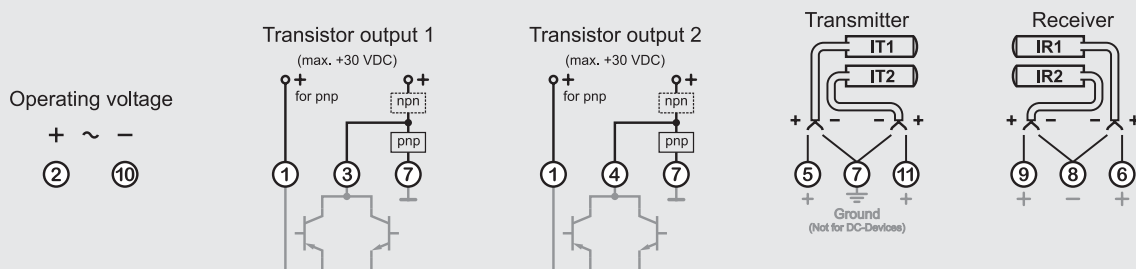

2-channel multiplex Amplifier **IMX-N34**

- Detection range up to 50 m
- Sensitivity adjustable with potentiometer
- Basic transmit level 2-fold selectable
- Switching behaviour light / dark selectable
- Multiplex speed 2-fold selectable
- Switching delay
- Relay output, normally open

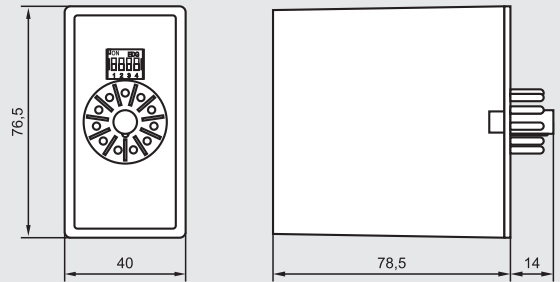

in mm

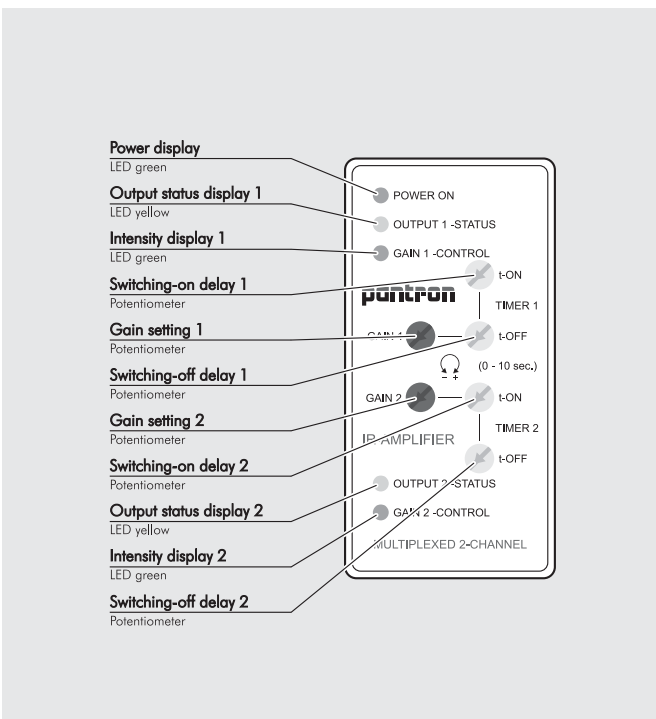

Technical data (at +20°C)

Operating voltage	see purchase order table
Operating basis	modulated infrared light
Transmit frequency	4,0 kHz
Transmit power	manual
Switching behaviour	light / dark
Basic transmit level	low / high
Multiplex speed	8 ms / 16 ms
Switching delay	0 ... 15 s
Light curtain	-
Master-Slave	-
Switching output	Relay, 2x normally open
max. operation value	5 A / 230 V AC (24 V DC)
reaction time	Multiplex speed 8 ms (16 ms): 16 ms (32 ms)
Alarm output	-
Test input	-
Housing material	plastic
Protection class	IP 40
Connection	11-pin DIN-plug
Operation temperature	-25 °C ... +50 °C

Purchase order table

Operating voltage	Order table
230 V AC / ±10 % / 4,1 VA	IMX-N34/230VAC
115 V AC / ±10 % / 4,1 VA	IMX-N34/115VAC
24 V AC / ±10 % / 4,1 VA	IMX-N34/24VAC
24 V DC / ±20 % / 2,0 W	IMX-N34/24VDC

Accessories

11-pole DIN-socket	ISO1
Protective enclosure	PanBox 1x2

Maximum Range

	Receiver IRL-...	Receiver IR-...
Transmitter IT-..., ITL-...	10 m	20 m
Transmitter IT-...HP..., ITH-...	15 m	30 m
Transmitter ITA-...	25 m	50 m

Amplifier mode (Factory setting is marked in white)



1		2		3		4	
Switching behaviour channel 1		Switching behaviour channel 2		Basic transmit level		Multiplex speed	
dark	ON	dark	ON	high	ON	16 ms	ON
light	OFF	light	OFF	low	OFF	8 ms	OFF

Connection diagram

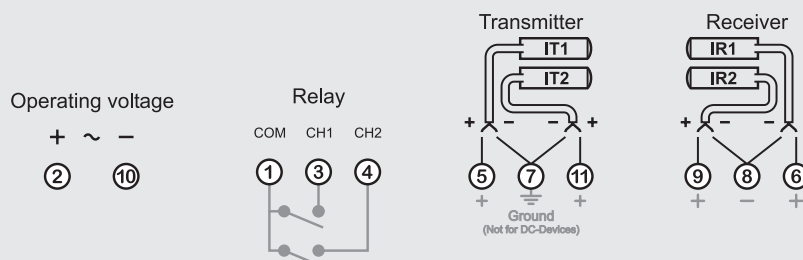

IMX-Series

4-channel multiplex Amplifier **IMX-N440**

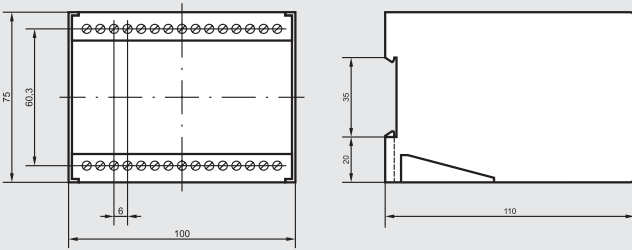

in mm

- Detection range up to 40 m
- Sensitivity adjustable with potentiometer
- Basic transmit level 2-fold selectable
- Switching behaviour light / dark selectable
- Multiplex speed 2-fold selectable
- Switching delay for channel 1
- Relay output, change over
- Master-Slave
- Mounting for DIN rail

Technical data (at +20°C)

Operating voltage	see purchase order table
Operating basis	modulated infrared light
Transmit frequency	4,0 kHz
Transmit power	manual
Switching behaviour	light / dark
Basic transmit level	low / high
Multiplex speed	16 ms / 32 ms
Switching delay	0 ... 15 s
Light curtain	yes
Master-Slave	yes
Switching output	Relay, 4x change over
max. operation value	5 A / 230 V AC (24 V DC)
reaction time	Multiplex speed 16 ms (32 ms): 16 ms (32 ms)
Alarm output	-
Test input	-
Housing material	plastic
Protection class	IP 20
Connection	Screw terminals
Operation temperature	-25 °C ... +50 °C

Purchase order table

Operating voltage	Order table
230 V AC / ±10 % / 6,0 VA	IMX-N440/230VAC
115 V AC / ±10 % / 6,0 VA	IMX-N440/115VAC
24 V AC / ±10 % / 6,0 VA	IMX-N440/24VAC
24 V DC / ±20 % / 4,5 W	IMX-N440/24VDC

Accessories

Protective enclosure	PanBox 1x4
----------------------	------------

Maximum Range

	Receiver IRL-...	Receiver IR-...
Transmitter IT-..., ITL-...	10 m	20 m
Transmitter IT-...HP-..., ITH-...	15 m	30 m
Transmitter ITA-...	20 m	40 m

Connection diagram

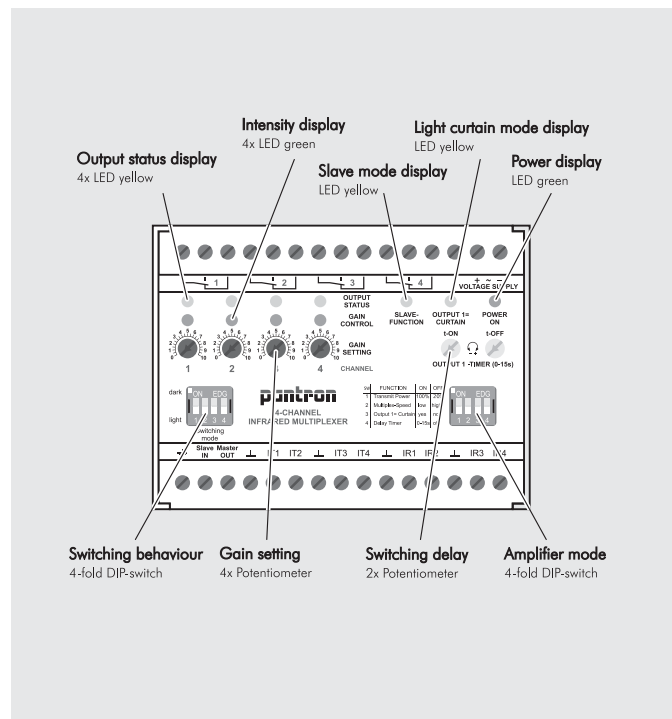
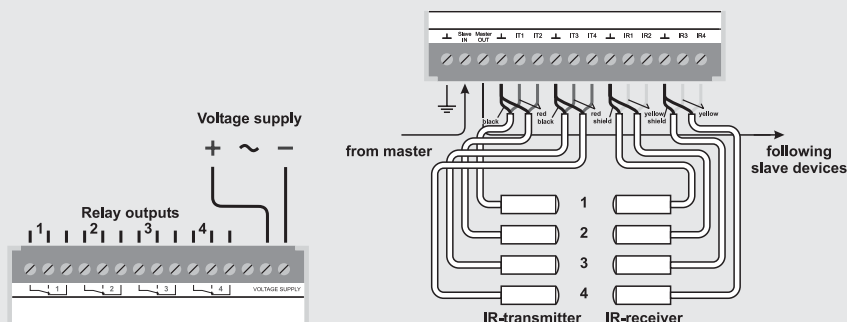

Amplifier mode (Factory setting is marked in white)



1		2		3		4	
Basic transmit level		Multiplex speed		Light curtain		Switching delay	
high	ON	32 ms	ON	on	ON	on	ON
low	OFF	16 ms	OFF	off	OFF	off	OFF

8-channel multiplex Amplifier **IMX-N840**

- Detection range up to 40 m
- Sensitivity adjustable with potentiometer
- Basic transmit level 2-fold selectable
- Switching behaviour light / dark selectable
- Multiplex speed 2-fold selectable
- Switching delay for channel 1
- Relay output, normally open
- Master-Slave
- Mounting for DIN rail

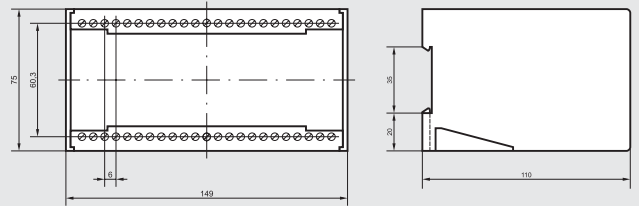

in mm

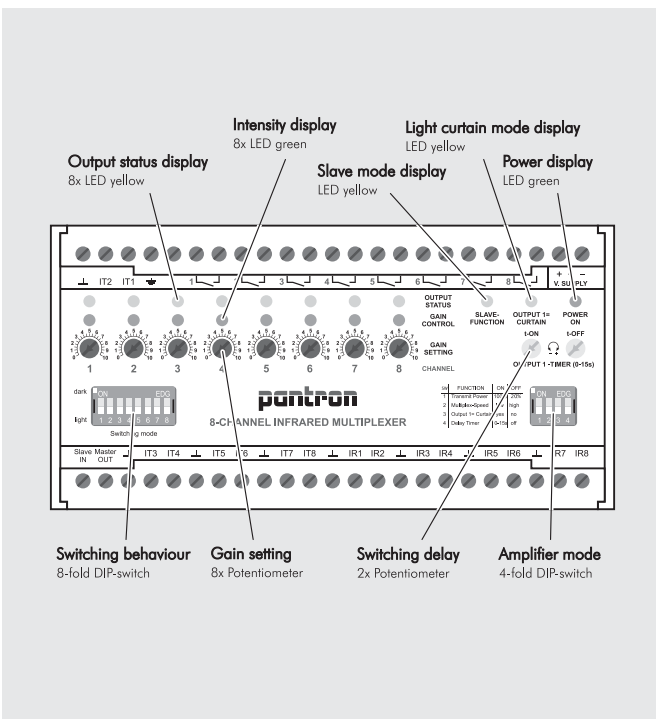

Technical data (at +20°C)

Operating voltage	see purchase order table
Operating basis	modulated infrared light
Transmit frequency	4,0 kHz
Transmit power	manual
Switching behaviour	light / dark
Basic transmit level	low / high
Multiplex speed	34 ms / 68 ms
Switching delay	0 ... 15 s
Light curtain	yes
Master-Slave	yes
Switching output	Relay, 8x normally open
max. operation value	5 A / 230 V AC (24 V DC)
reaction time	Multiplex speed 34 ms (68 ms): 34 ms (68 ms)
Alarm output	-
Test input	-
Housing material	plastic
Protection class	IP 20
Connection	Screw terminals
Operation temperature	-25 °C ... +50 °C

Purchase order table

Operating voltage	Order table
230 V AC / ±10 % / 6,0 VA	IMX-N840/230VAC
115 V AC / ±10 % / 6,0 VA	IMX-N840/115VAC
24 V AC / ±10 % / 6,0 VA	IMX-N840/24VAC
24 V DC / ±20 % / 4,5 W	IMX-N840/24VDC

Accessories

Protective enclosure	PanBox 1x8
----------------------	------------

Maximum Range

	Receiver IRL-...	Receiver IR-...
Transmitter IT-..., ITL-...	10 m	20 m
Transmitter IT-...HR..., ITH-...	15 m	30 m
Transmitter ITA-...	20 m	40 m

Amplifier mode (Factory setting is marked in white)



	1	2	3	4
Basic transmit level	high	Multiplex speed	Light curtain	Switching delay
high	ON	68 ms	on	ON
low	OFF	34 ms	off	OFF

Connection diagram

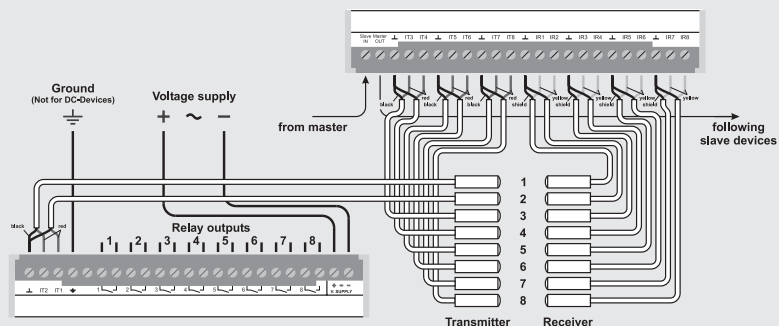

IMX-Series

2-channel multiplex Amplifier **IMX-A2034**

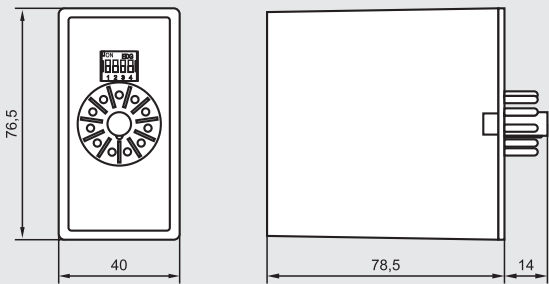

in mm

- Detection range up to 40 m
- Automatic transmit power adjustment
- Test function
- Basic transmit level 4-fold selectable
- Switching behaviour light / dark selectable
- Switching delay
- Relay output, normally open

Technical data (at +20°C)

Operating voltage	see purchase order table
Operating basis	modulated infrared light
Transmit frequency	4,0 kHz
Transmit power	automatic
Switching behaviour	light / dark
Basic transmit level	low1 / low2 / high1 / high2
Multiplex speed	4 ms
Switching delay	0 ... 15 s
Light curtain	-
Master-Slave	-
Switching output	Relay, 2x normally open
max. operation value	5 A / 230 V AC (24 V DC)
reaction time	8 ms
Alarm output	-
Test input	-
Housing material	plastic
Protection class	IP 40
Connection	11-pin DIN-plug
Operation temperature	-25 °C ... +50 °C

Purchase order table

Operating voltage	Order table
230 V AC / ±10 % / 4,1 VA	IMX-A2034/230VAC
115 V AC / ±10 % / 4,1 VA	IMX-A2034/115VAC
24 V AC / ±10 % / 4,1 VA	IMX-A2034/24VAC
24 V DC / ±20 % / 2,0 W	IMX-A2034/24VDC

Accessories

11-pole DIN-socket	ISO1
Protective enclosure	PanBox 1x2

Maximum Range

	Receiver IRL-...	Receiver IR-...
Transmitter IT-..., ITL-...	7 m	13 m
Transmitter IT-...HP-..., ITH-...	9 m	20 m
Transmitter ITA-...	15 m	40 m

Connection diagram

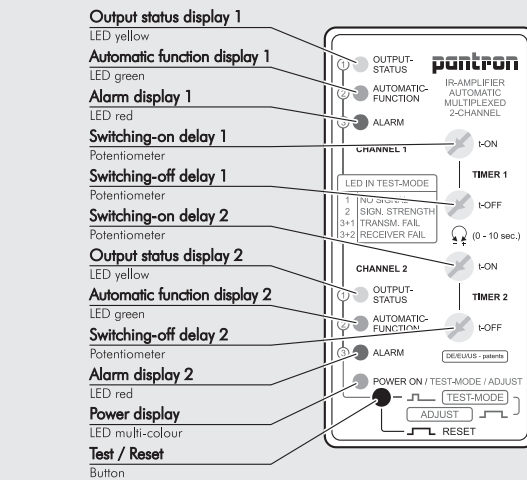
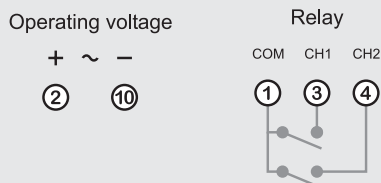

Amplifier mode (Factory setting is marked in white)



	1	2	3	4	5	6
	channel 1			channel 2		
Basic transmit level	ON	ON	ON	ON	ON	ON
Switching behaviour	dark	ON	ON	dark	ON	ON
high2	ON	OFF	ON	ON	OFF	ON
high1	ON	OFF	ON	ON	OFF	ON
low2	OFF	ON	OFF	OFF	ON	OFF
low1	OFF	OFF	light	OFF	OFF	light

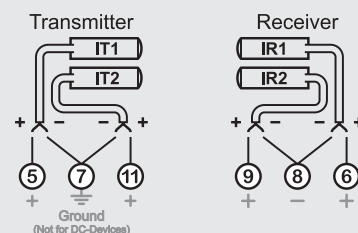

8-channel multiplex Amplifier **IMX-A840**

- Detection range up to 55 m
- Automatic transmit power adjustment
- Test function
- Basic transmit level 2-fold programmable
- Switching behaviour light / dark programmable
- Switching delay
- Relay output, normally open
- Alarm output
- Sensor control
- Master-Slave
- Mounting for DIN rail

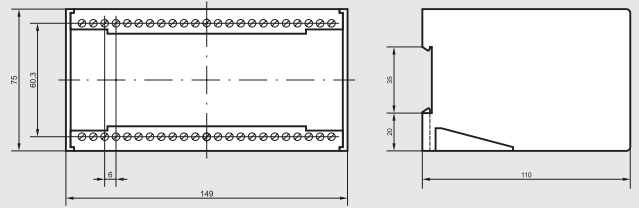

in mm

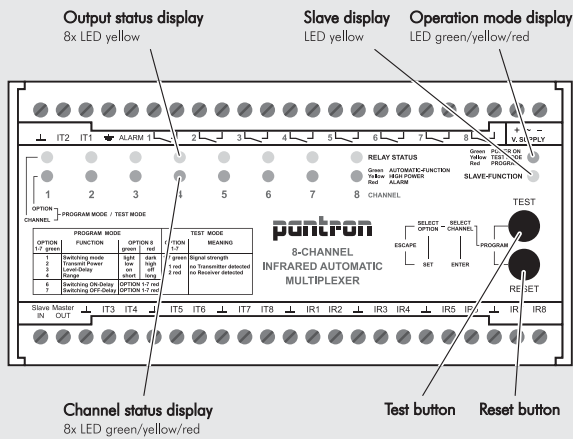

Technical data (at +20°C)

Operating voltage	see purchase order table
Operating basis	modulated infrared light
Transmit frequency	4,0 kHz
Transmit power	automatic
Switching behaviour	light / dark
Basic transmit level	low / high
Multiplex speed	36 ms
Switching delay	0 ... 7 s
Light curtain	-
Master-Slave	yes
Switching output	Relay, 8x normally open
max. operation value	5 A / 230 V AC (24 V DC)
reaction time	36 ms
Alarm output	pnp, 100 mA / 24 V DC (...AC: 5 mA)
Test input	-
Housing material	plastic
Protection class	IP 20
Connection	Screw terminals
Operation temperature	-25 °C ... +50 °C

Purchase order table

Operating voltage	Order table
230 V AC / ±10 % / 6,0 VA	IMX-A840/230VAC
115 V AC / ±10 % / 6,0 VA	IMX-A840/115VAC
24 V AC / ±10 % / 6,0 VA	IMX-A840/24VAC
24 V DC / ±20 % / 4,5 W	IMX-A840/24VDC

Accessories

Protective enclosure	PanBox 1x8
----------------------	------------

Maximum Range

	Receiver IRL-...	Receiver IR-...
Transmitter IT-..., ITL-...	8 m	15 m
Transmitter IT-...HR..., ITH-...	10 m	20 m
Transmitter ITA-...	20 m	55 m

Connection diagram

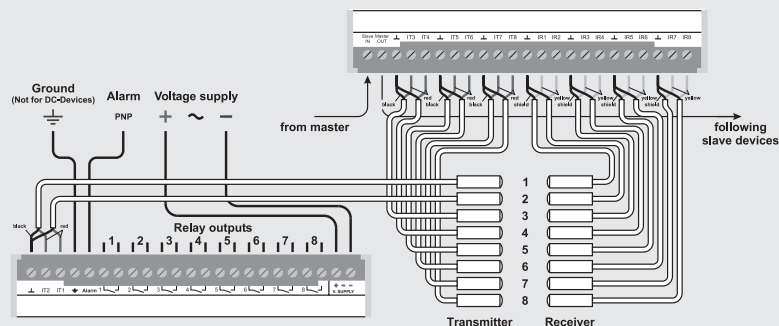

Accessories

Protective enclosure **PanBox**

- Impact resistant polycarbonate
- Transparent top cover
- Protection class IP66
- Cable gland M12 and M16

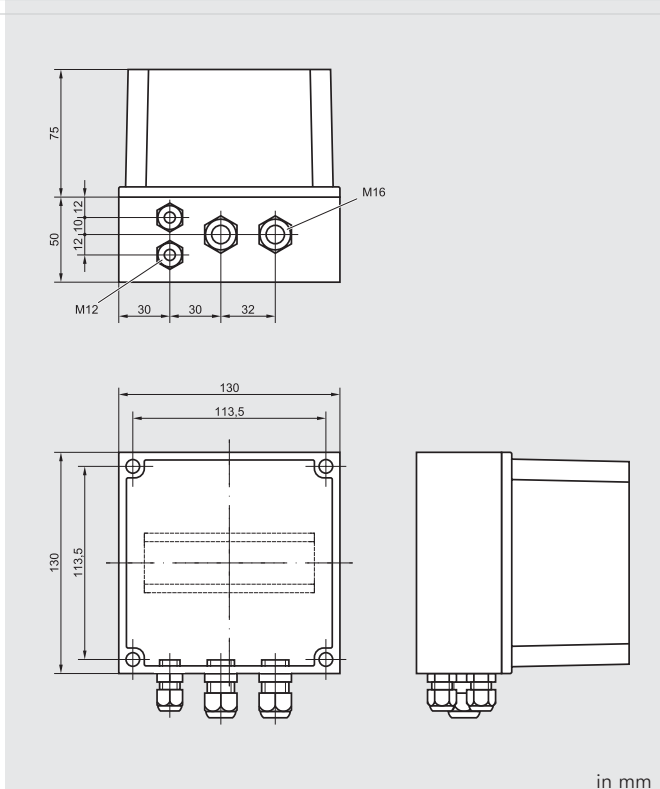

in mm

Protective enclosure PanBox 1x1
for one 1-channel Amplifier

Protective enclosure PanBox 1x2
for one 2-channel Amplifier

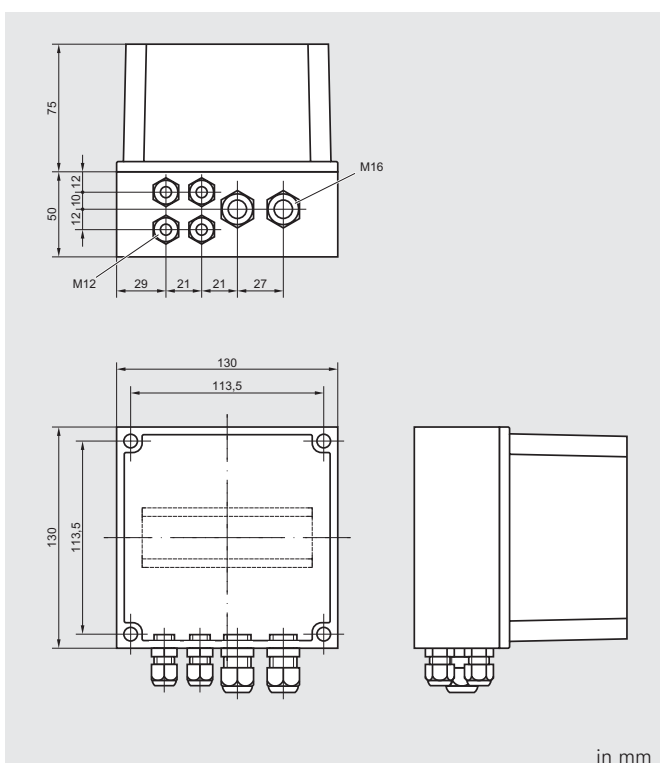

in mm

Technical data (at +20°C)

Housing material	
Cover	Glass fiber reinforced polycarbonate
Top cover	Polycarbonate
Ingress protection (EN 60529)	IP 66
Impact resistance (EN 50102)	IK 08
Colour	
Cover	Gray
Top cover	Smokey
Gasket	Polyurethane
Enclosure flammability rating	UL94-5V
Ambient temperature	-40 °C ... +120 °C
Permanent temperature	-40 °C ... +80 °C

Purchase order table

Description	Order code
for one 1-channel Amplifier	PanBox 1x1
for three 1-channel Amplifier	PanBox 3x1
for one 2-channel Amplifier	PanBox 1x2
for one 4-channel Amplifier	PanBox 1x4
for one 8-channel Amplifier	PanBox 1x8

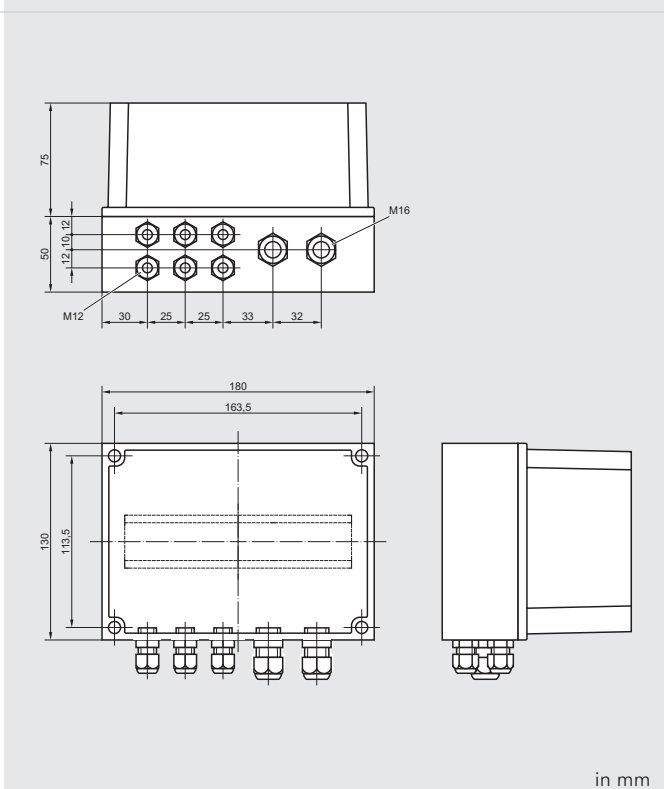

Protective enclosure PanBox 3x1
for three 1-channel Amplifier

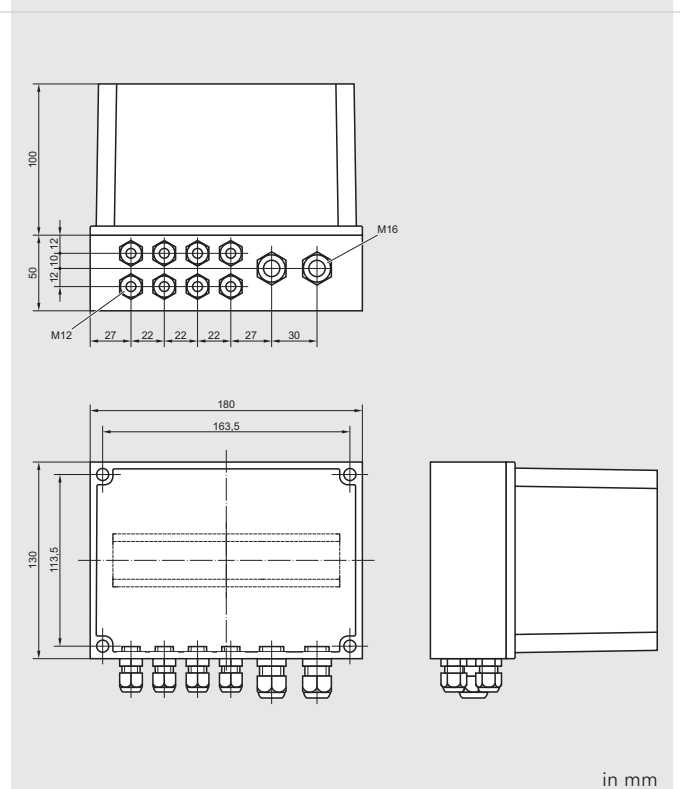

Protective enclosure PanBox 1x4
for one 4-channel Amplifier

Protective enclosure PanBox 1x8
for one 8-channel Amplifier

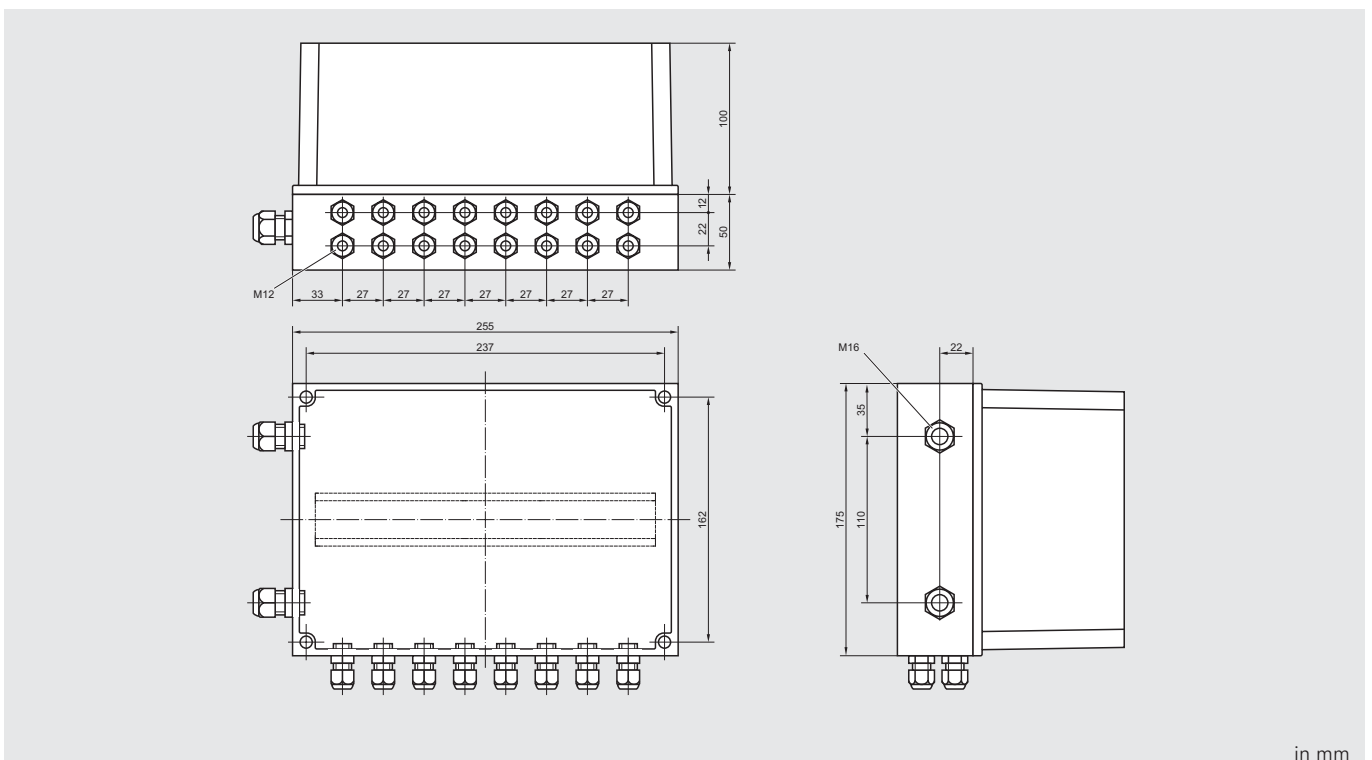

in mm

Accessories

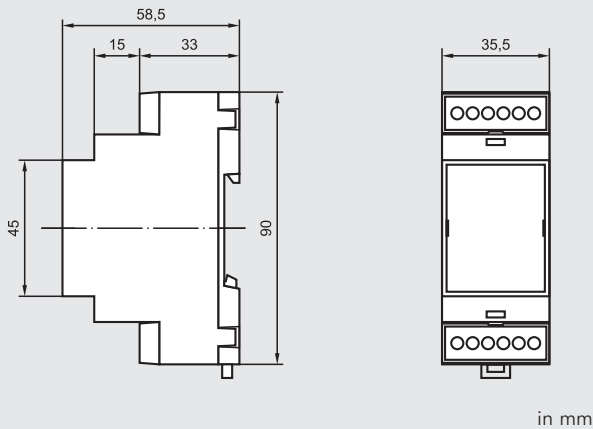

in mm

Power supply unit **PSU-1000**

- Wide input voltage range 95 ... 265 V AC / 47 ... 63 Hz
- Output voltage 24 V DC
- Output power 8,4 W
- Overload protection, short circuit proof
- Overtemperature protection
- External fuse is not necessary
- High Efficiency >74 %
- Switching on current limiter
- Mounting for DIN rail

Technical data (at +20°C)

Operating voltage	95 V AC ... 265 V AC
Power consumption	max. 8,5 VA
Output voltage	24 V DC, short circuit proof
Voltage tolerance	± 5 %
Output load	400 mA
Housing material	NORYL, grey
Protection class	IP 20
Connection	see purchase order table
Operation temperature	-25 °C ... +50 °C

Purchase order table

Connection	Order code
Screw terminals	PSU-1000S/95...265VAC

Accessories

Protective enclosure	PanBox 1x1
----------------------	------------

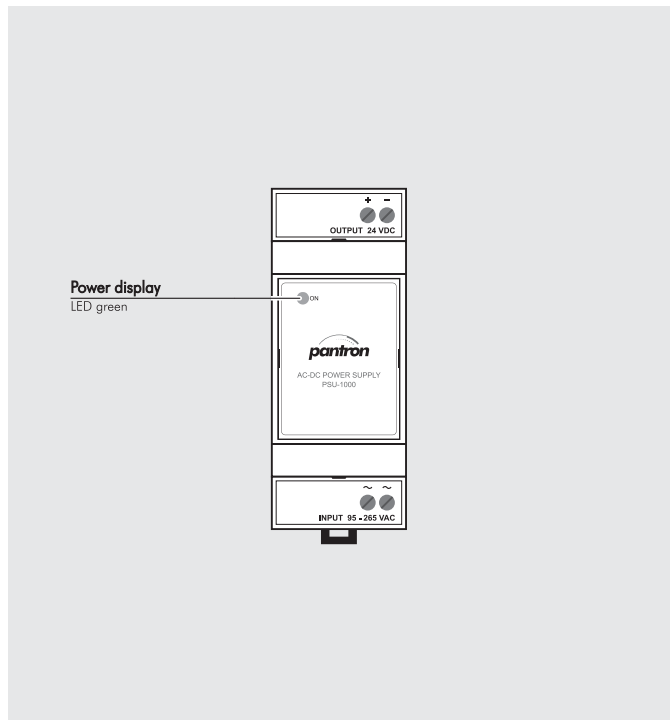

Connection diagram

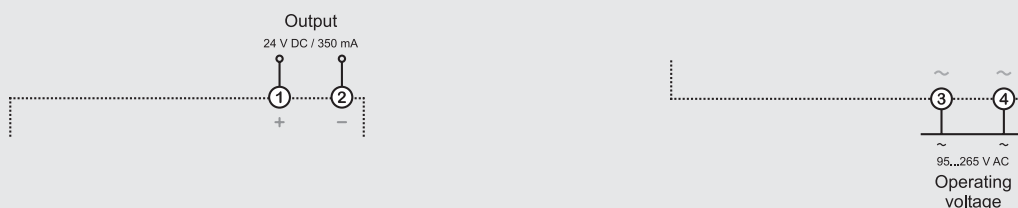

Accessories

11-pole DIN-socket

Purchase order table

Description	Order code
for connecting and DIN-rail mounting or amplifier with DIN-plug	ISO1



Retaining clip

Purchase order table

Description	Order code
for a reliable mounting of amplifiers on the DIN-socket by vibrations	RTC



Measurement cable

Purchase order table

Description	Order code
for connecting a measurement unit to the analog output of the amplifier ISG-N124M	CAB-TEST-4m



Communication cable

Purchase order table

Description	Order code
connection cable for programming the amplifiers ISM-4000 / ISM-8000 via Computer	CAB-COM-2m





Pantron Instruments GmbH

Süllbergstr. 3-5 · D-31162 Bad Salzdetfurth · Phone: 0 50 63/95 91-0 · Fax: 0 50 63/95 91-55 · E-Mail: info@pantron.de · www.pantron.com

Product overview

- High performance light barriers
- Compact light barriers
- Miniature opto sensors
- Fork light barriers
- Angled light barriers
- Area light barriers
- Inductive proximity switches
- Ring sensors
- Capacitive level probe
- Ultrasonic sensors

